

IOM manual

tapflo®

# PE & PTFE Diaphragm Pumps

edition 2016 rev 1



Read this instruction manual carefully,  
before you install and operate the pump.



Pump models:

TR/TXR9

TR/TXR20

T/TX50

T/TX100

T/TX200

T/TX400

T800



» All about your flow

[www.tapflo.com](http://www.tapflo.com)

# CONTENTS

---

<b>0. GENERAL</b> .....	6
<b>0.1. Introduction</b> .....	6
<b>0.2. Warning symbols</b> .....	6
<b>0.3. Qualification and training of personnel</b> .....	6
<b>1. INSTALLATION</b> .....	7
<b>1.1. Operation principle</b> .....	7
<b>1.2. Receiving inspection</b> .....	7
<b>1.3. Storage</b> .....	8
<b>1.4. Foundation</b> .....	8
<b>1.5. Suction and discharge piping</b> .....	8
<b>1.5.1. Rotary connections</b> .....	8
<b>1.5.2. Connection of suction pipe</b> .....	8
<b>1.5.3. Connection of discharge pipe</b> .....	8
<b>1.6. Health and safety</b> .....	9
<b>1.6.1. Protection</b> .....	9
<b>1.6.2. Explosion hazardous environments – ATEX</b> .....	9
<b>1.6.3. Air pressure</b> .....	9
<b>1.6.4. Noise level</b> .....	10
<b>1.6.5. Temperature hazards</b> .....	10
<b>1.7. Air connection</b> .....	10
<b>1.7.1. Air treatment system</b> .....	11
<b>1.8. Example of installation</b> .....	11
<b>1.9. Recommended installations</b> .....	12
<b>1.9.1. Flooded</b> .....	12
<b>1.9.2. Self-priming</b> .....	12
<b>1.9.3. Submerged</b> .....	12
<b>2. OPERATION</b> .....	13
<b>2.1. Before starting the pump</b> .....	13
<b>2.2. Starting and operation</b> .....	13
<b>2.2.1. Dry running</b> .....	13
<b>2.2.2. Optimization of the pump lifetime</b> .....	13
<b>2.3. Pump stopping</b> .....	14
<b>3. MAINTENANCE</b> .....	15
<b>3.1. When the pump is new or reassembled</b> .....	15
<b>3.1.1. Performance test</b> .....	15

# CONTENTS

---

3.2.	Routine inspection .....	15
3.3.	Complete inspection .....	15
3.4.	Location of faults .....	16
3.5.	TR9 / TR20 – Disassembly of the pump .....	17
3.5.1.	Before the disassembly procedure .....	17
3.5.2.	Disassembly procedure .....	17
3.6.	TR9 / TR20 – Assembly of the pump .....	19
3.6.1.	Test run .....	19
3.7.	T50-T800 – Disassembly of the pump .....	20
3.7.1.	Before the disassembly procedure .....	20
3.7.2.	Disassembly procedure .....	20
3.8.	T50-T800 – assembly of the pump .....	24
3.8.1.	Test run .....	24
4.	OPTIONS .....	25
4.1.	Drum pump – TD... .....	25
4.2.	Twin connections – TT... .....	25
4.3.	Filter press pump – TF... .....	26
4.4.	Barrier pump – TB... .....	26
4.5.	Pump with built-on dampener – TK ... .....	27
4.6.	Pump with integrated flanges – T... -3D/-3A .....	27
5.	SPARE PARTS .....	29
5.1.	TR9 and TR20 – Spare parts drawing .....	29
5.2.	TR9 and TR20 – Spare parts list .....	30
5.3.	T50-T100 – Spare parts drawing .....	31
5.4.	T50-T100 – Spare parts list .....	31
5.5.	T50-T100 – Spare parts - Options .....	32
5.6.	T200-T400 – Spare parts drawing .....	34
5.7.	T200-T400 – Spare parts list .....	34
5.8.	T200-T400 – Spare parts - Options .....	35
5.9.	T800 – Spare parts drawing .....	37
5.10.	T800 – Spare parts list .....	38
5.11.	Stocking recommendation .....	39
5.12.	How to order parts .....	40
5.13.	Pump code .....	40
6.	DATA .....	41
6.1.	Capacity curves .....	41

# CONTENTS

---

6.2.	Capacity changes .....	42
6.3.	Technical data.....	42
6.4.	Dimensions.....	43
6.5.	Tightening torques .....	45
6.6.	Permitted loads on manifolds.....	45
7.	WARRANTY.....	46
7.1.	Warranty form.....	46
7.2.	Returning parts.....	47
7.3.	Warranty.....	47

## EC declaration of conformity

Machinery directive 2006/42/EC

Pressure equipment directive 97/23/EC, Category I

Tapflo AB declares that:

Product name: Air operated diaphragm pumps  
Models: T...

is in conformity with the essential health and safety requirements and technical construction file requirements of the EC Machinery directive 2006/42/EC,

and is in conformity with the Pressure Equipment Directive (PED) 97/23/EC Category I.

Manufactured by Tapflo Sp. z o. o., Poland for:

Tapflo AB  
Filaregatan 4  
S-442 34 Kungälv  
Sweden

Tapflo AB, January 2nd 2013



Håkan Ekstrand  
*Managing director*

# 0. GENERAL

---

## 0. GENERAL

### 0.1. Introduction

The Tapflo Air Operated Diaphragm Pump range is a complete series of pumps for industrial applications. The pumps are designed to be safe, simple and easy to use and maintain. The construction is seal-less and without rotating parts. The pumps are suitable for almost all different chemicals used by the industry today.

With proper attention to maintenance, Tapflo Pumps will give efficient and trouble free operation. This instruction manual will familiarise operators with detailed information about installing, operating and maintaining of the pump.

### 0.2. Warning symbols

The following warning symbols are present in this instruction manual. This is what they say:



This symbol stands next to all safety instructions in this instruction manual where danger to life and limb may occur. Observe these instructions and proceed with utmost caution in these situations. Inform also other users of all safety instructions. In addition to the instructions in this instruction manual, the general safety and accident prevention regulations must be observed.



This signal stands at points in this instruction manual of particular importance for compliance with regulations and directives, for correct work flow and for the prevention of damage to and destruction of the complete dampener or its subassemblies.

### 0.3. Qualification and training of personnel



The personnel in charge of installation, operation and maintenance of the pumps we produce must be qualified to carry out the operations described in this manual. Tapflo shall not be held responsible for the training level of personnel and for the fact that they are not fully aware of the contents of this manual.



# 1. INSTALLATION

---

## 1.3. Storage



If the equipment is to be stored prior to installation, place it in a clean location. The pump should be stored in an ambient temperature of 15°C (59°F) to 25°C (77°F) and relative humidity below 65%. It should not be exposed to any heat source e.g. radiator, sun as this could result in a negative way on the tightness of the pump. Do not remove the protective covers from the suction, discharge and air connections which have been fastened to keep pump internals free of debris. Clean the pump thoroughly before installation.

## 1.4. Foundation



The pump is equipped with vibration absorbing rubber feet. The pump will operate properly without being fixed to a foundation. If fixation is needed for installation purposes, make sure the foundation is able to absorb vibrations. It is essential for the operation of the pump to mount the pump with the feet in a downward direction (see sketch in chapter 1.8 "Example of installation").

## 1.5. Suction and discharge piping

Suction and discharge piping should be fully supported and anchored near to but independent of the pump. The piping connected to the pump should be a hose, to prevent undue stress and strain on the pump connections and the piping.

### 1.5.1. Rotary connections

The suction and discharge connections can be rotated 180°. This simplifies the assembly and installation of the pump. If you wish to rotate the connections, screw a threaded nipple into the connection and rotate it. On the larger models T200, T400 and T800 it will be easier if the housing nuts are slightly released while turning the connections.

### 1.5.2. Connection of suction pipe

Remember that the suction pipe/connection is the most critical point, especially if the pump is priming. Just a small leakage will dramatically reduce the suction capability of the pump. When connecting the suction pipe, the following is recommended:

- 1) For satisfactory operation, use a reinforced hose (the suction power may otherwise shrink the hose) or other flexible piping. The internal diameter of the hose should be the same as on the suction connection (at the bottom of the pump) to have best suction capability.
- 2) Make sure that the connection between the hose and the pump is completely tight, otherwise the suction capability will be reduced.
- 3) Always use as short suction pipe as possible. Avoid air pockets which can emerge with long piping.

### 1.5.3. Connection of discharge pipe

For this connection it is only recommended to have a simple and positive flow connection. Use a hose or flexible piping (minimum one meter) between the discharge connection and any rigid fixed piping. Coil the hose at least one turn. All components (hose, pipe, valves etc.) on the discharge piping must be designed for minimum PN 10.



# 1. INSTALLATION

---

## 1.6. Health and safety

The pump must be installed according to local and national safety rules.



**The pumps are constructed for particular applications. Do not use the pump on applications different from that for which it was sold without consulting us to ascertain its suitability.**

### 1.6.1. Protection



In the interest of health and safety it is essential to wear protective clothing and safety goggles when operating, and/or working in the vicinity of Tapflo pumps.

### 1.6.2. Explosion hazardous environments – ATEX



The standard PE & PTFE series pumps are not allowed to operate in environments where there is danger of explosion. Static electricity may occur in the pump under operation, which may cause explosion and injury. Special conductive TX pumps are available for such applications. Follow below instructions and local/national rules for safe use.

ATEX (directive 94/9/EC) classification of Tapflo TX pumps:

#### **ATEX II 2 GD IIB c T4**

Equipment group: **II** – all other explosive areas than mines;  
Category group: **2** – high level of protection (can be used in zone 1);  
Atmosphere: **G** – gas;  
**D** – dust;  
Explosion group: **IIB** – such as ethylene;  
Type of protection: **c** – constructional safety;  
Temperature class: **T4** – in the event of a malfunction, the maximum temperature of a surface that may be exposed to gas **T4** = 135 °C.

#### **Earth connection of the pump and other equipment**

Connect a suitable earth wire to the stainless steel earth connection that is placed on the inside of one of the pump housings. Connect the other end of the earth wire to earth and also make sure that other equipment like hoses/pipes/containers etc. are properly earthed/connected.

### 1.6.3. Air pressure

The maximum air pressure for Tapflo pumps is 8 bar. Higher air pressure than 8 bar can damage the pump and may cause injury to personnel in vicinity of the pump. If you intend to apply a higher air pressure than 8 bar, please consult us.

# 1. INSTALLATION

---

## 1.6.4. Noise level



At tests, the noise level from a Tapflo pump has not exceeded 80 dB(A). Under some circumstances, for example if the pump is operating under high air pressure at low discharge head, the noise can be inconvenient or hazardous for personnel staying for long periods in the vicinity of the pump. This hazard can be prevented by:

- using suitable ear protection;
- lowering the air pressure and/or raising the discharge head;
- leading out the outgoing air from the room by connecting a hose to the muffler connection of the pump;
- using elastomer valve balls (EPDM, NBR or polyurethane) instead of PTFE, ceramic or stainless steel, provided that the elastomer is compatible with the pumped liquid.

## 1.6.5. Temperature hazards

- Raised temperature can cause damage on the pump and/or piping and may also be hazardous for personnel in the vicinity of the pump/piping. Avoid quick temperature changes and do not exceed the maximum temperature specified when the pump was ordered. See also general max temperatures based on water in chapter 6 "DATA".



- When the pump is exposed to ambient temperature variations or if there is big difference between the temperature of the product and the surrounding, the tightening torques of the housing nuts should be checked periodically as part of preventive maintenance.

- If a hot product is pumped, the pump should not stand still when filled for a longer period of time. This could cause leakage from the valves and contamination and/or damage of the air valve.

- Below 0°C (32°F) plastic materials become more fragile what can cause accelerated wear of parts made of these materials. This is a hazard that has to be accepted when pumping such cold products. Also in such case, when a pump is not operational it should be drained of all liquid.



- Bear in mind that the viscosity of the product changes with temperature. This has to be taken into consideration when selecting the pump.

## 1.7. Air connection

Screw the air hose into the air intake on the centre block of the pump with for example a quick release coupling. For best efficiency, use the same hose diameter as the internal diameter of the connection on the air intake.

# 1. INSTALLATION

## 1.7.1. Air treatment system



The air valve is constructed for oil-free air. Lubrication of the air is **not allowed**. However, if the air is **very dry** (laboratory air), the air may be lubricated with water. Maximum air pressure is 8 bar. As prevention purpose, a filtration of the air by means of a 5 micron filter or finer is recommended. Recommended air quality according to PN-ISO8573-1:2010 is particles class 6, water class 7 and oil class 4. Dirt in the air can under unfortunate circumstances be the cause of a breakdown.

To facilitate the operation of the pump we recommend an air treatment system connected to the air supply. These components should be included:

- 1) Regulator to adjust the air pressure;
- 2) Manometer to read the actual pressure;
- 3) Needle valve to adjust the air flow (especially when operating the pump in the lower range of performance);
- 4) Filter.

These components are included in Tapflo's **Air treatment system** which can be ordered from us.

## 1.8. Example of installation

- 1) Gate valve compressed air
- 2) Filter and pressure regulator
- 3) Flexible hose
- 4) Needle valve
- 5) Flexible piping
- 6) Gate valve suction
- 7) Gate valve discharge
- 8) Coiled flexible piping
- 9) Flow gauge

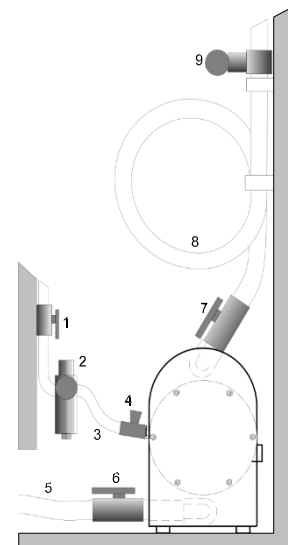

# 1. INSTALLATION

## 1.9. Recommended installations

The Tapflo pump is flexible in the way you are able to install it. The in- and outlet ports can be rotated more than 180° to fit various piping systems.

### 1.9.1. Flooded

The piping system is designed with a positive suction head. This is the best way of installation where it is necessary to completely empty all liquid from the container, or where viscous (thick) products are transferred.



**NOTE! Do not exceed 0,7 bar suction pressure! Higher pressure may cause premature diaphragm failure and irregular pump operation.**

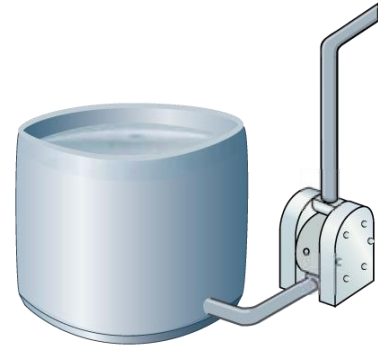

### 1.9.2. Self-priming

The Tapflo pump is designed to pull a high vacuum. It is able to evacuate an empty suction pipe without any damage to the pump. The suction lift is up to 5 meters (16.4 ft.) from an empty suction pipe and up to 8 meters (26.2 ft.) from a wetted pipe. The suction capability depends on the pump size (see chapter 5 "DATA").

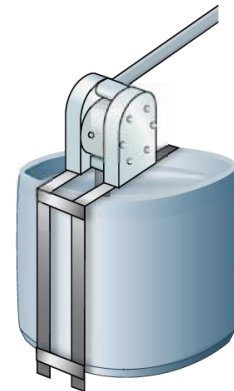

### 1.9.3. Submerged

All Tapflo pumps may be submerged into the liquid. It is important to make sure that all components which are in contact with the liquid are chemically compatible. The air exhaust must be led to the atmosphere by means of a hose.



#### **NOTE!**

Even if all above safety instructions are met and complied with, there still exists a minor danger in the event of a leakage or mechanical damage of the pump. In such case the pumped product can emerge on sealing areas and connections.

## 2. OPERATION

---

### 2. OPERATION

#### 2.1. Before starting the pump



- Make sure the pump is installed according to the installation instruction (chapter 1).

- Filling of the pump with liquid before start is not necessary.

- When installation is new or reinstalled, a test run of the pump with water should be conducted to make sure that the pump operates normally and does not leak.



- When installation is new or reinstalled, check the pump housing nuts tightening torque (see chapter 5.5 "Tightening torques"). After approximately one week of operation, the torque should be checked again. This is important to prevent possible leakage.

#### 2.2. Starting and operation

- Open the discharge valve.

- **Note! Considering the suction capacity when air is still in the suction pipe, it is recommended to start with low air pressure/flow (slowly) at the beginning. This is not necessary if the pump is filled with liquid before start.**

- When the pump has been filled with liquid, the air pressure/flow may be raised in order to increase the suction capacity of the pump.

- The performance of the pump can be adjusted through the air supply by using a needle valve and a pressure regulator. The performance can also be adjusted by normal flow control on the discharge side of the system.

##### 2.2.1. Dry running

Although the pump is prepared for dry running it is important to have in mind that long periods of dry run may cause damage to the air valve and circlips. Also an empty pump should operate at low speeds – controlled by a needle-valve.

##### 2.2.2. Optimization of the pump lifetime

- Running at full frequency (maximum air pressure/flow) continuously will cause premature wear of the components. When there is possibility of the pump running dry or/and at full frequency it is recommended to use an air valve with a PET piston. As a general rule, we recommend to run at half of the maximum capacity of the pump. For instance, a T100 pump should run continuously at maximum 50 l/min.



- As stated in chapter 0 Tapflo recommends to use an appropriate air treatment system in order to extend the pump's lifetime.

- If the air humidity is high, use of a water separator or air dryer is recommended. Otherwise on the air discharge side due to decompression, icing on the muffler can appear causing it to shrink and eventually it can shoot out of its socket.

- If the ambient air is humid, icing can occur outside of the muffler. In such case it is recommended to use a longer exhaust of the compressed air (ca. 500 mm / 19,7").

## 2. OPERATION

---

- If there is possibility of freezing at the air exhaust, it is good to pre-heat the air before it reaches the air intake in order to raise the dew point of the air.  
**NOTE!** Make sure that the air temperature does not exceed 50°C (122°F).
- If icing / freezing is still a problem with the standard muffler, we recommend using our heavy duty metal muffler. Contact us for more information.

### 2.3. Pump stopping

The pump can be stopped in two ways:

- 1) By closing of the discharge valve. The pressure from the system will stop the pump automatically. The pump restarts easily when the valve is opened again.  
**NOTE!** When using this method keep in mind that air must be supplied to the pump. This is essential to keep the diaphragms in balance what protects them from premature failure.
- 2) By cutting off the air supply.  
**NOTE!** When using this method make sure that the discharge valve is opened to relief the pumps pressure.

# 3. MAINTENANCE

---

## 3. MAINTENANCE

### 3.1. When the pump is new or reassembled



**If the pump is new or reassembled after maintenance it is important to retighten the pump housing nuts (pos. 37) after a few days of operation.**

Make sure to use the right torque – see chapter 5.5 *"Tightening torques"*.

#### 3.1.1. Performance test

When installation is new, a test run of the pump should be conducted. Gauge the capacity at specific air pressure/flow. This information is useful for checking performance in the future as wear takes place. You will be able to set schedules for maintenance of the pump and to select spare parts to be kept on stock.

### 3.2. Routine inspection



Frequent observation of the pump operation is recommended to detect problems. A change in sound of the running pump can be an indication of wearing parts (see chapter 3.4 *"Location of faults"* below).

Leaking liquid from the pump and changes of performance may also be detected. Routine inspections should be conducted frequently.

### 3.3. Complete inspection



The intervals for a complete inspection depend upon the operation conditions of the pump. The characteristics of the liquid, temperature, materials used in the pump and running time decide how often a complete inspection is necessary.

If a problem has occurred, or if the pump is in need of a complete inspection, refer to chapters 3.4 *"Location of faults"* and 3.5, 3.7 *"Dismantling of the pump"*. You are of course warmly welcome to consult us for further help.

Parts that are subject to wear should be kept in stock, see our recommendations in chapter 4.7 *"Stocking recommendation"*.

# 3. MAINTENANCE

## 3.4. Location of faults

PROBLEM	POSSIBLE FAULT	POSSIBLE SOLUTION
<b>The pump does not run</b>	The air pressure is too low The air connection is blocked Muffler is blocked Air valve is defective Dirt in the pump chamber Diaphragm breakdown	Increase air pressure via a filter-regulator Check / clean air supply connection Check / clean / replace muffler Clean / replace complete air valve Remove debris from the chambers Replace diaphragm
<b>The suction is bad</b>	Suction connection is not tight Suction connection is blocked Muffler is blocked Valve balls are blocked or damaged Valve seats are worn Pump starts with high pressure Air in suction / discharge line Dry suction against discharge pressure	Tighten the suction line Clean suction line Check / clean / replace muffler Check dimensions and shape of valve balls Check dimensions and shape of valve seats Start the pump slowly (see chapter 2.2) Vent suction / discharge line Wet the pump / start without discharge pressure
<b>The pump runs irregular</b>	Valve balls are blocked Sealing in centre block Air valve is defective Diaphragm breakdown Valve seats are worn Icing on the muffler	Check dimensions and shape of valve balls Replace sealing Clean / replace air valve Replace diaphragm Check dimensions and shape of valve seats Improve air quality (see chapters 1.7.1 and 2.2.2)
<b>Bad flow/pressure</b>	Pressure fall in air supply Pressure losses on suction side Air supply / air valve leaking Suction or air connection blocked Muffler is blocked Valve ball worn or broken Valve seats are worn Air in liquid Diaphragm breakdown Icing on the muffler	Increase air pressure via a filter-regulator Check/change installation on suction side Check / repair / replace air supply / air valve Check / clean air supply / suction connection Check / clean / replace muffler Check dimensions and shape of valve balls Check dimensions and shape of valve seats Seal suction line; check / refill container Check / replace diaphragms Improve air quality (see chapters 1.7.1 and 2.2.2)
<b>Liquid leaks from the pump</b>	Screws on the housing not properly tightened O-rings on manifolds damaged Damaged diaphragm Tension / stress from the installation	Check tightening torques of the screws  Replace O-rings Check / replace diaphragms Adjust installation, eliminate stress, when using a dampener provide separate support for it (see dampener IOM manual).
<b>Liquid comes out of the muffler</b>	Diaphragm breakdown	Replace diaphragm
<b>Diaphragm breakdown</b>	Wrong selection of material Too high pressure in the installation Long periods of dry running Too high pressure on suction side	Contact us for information on material selection Use air treatment system for protection When dry, run pump slowly (see chapter 2.2) Make sure there is pressure balance between the air and liquid side of the diaphragm



# 3. MAINTENANCE

## 3.5. TR9 / TR20 – Disassembly of the pump

The numbers put in brackets, refer to the part numbers in the spare part drawings and spare part lists in chapter 4 "SPARE PARTS".

### 3.5.1. Before the disassembly procedure



Be sure to drain all liquid from the pump. Cleanse or neutralize the pump thoroughly. Disconnect the air supply and then the suction and discharge connections.

### 3.5.2. Disassembly procedure

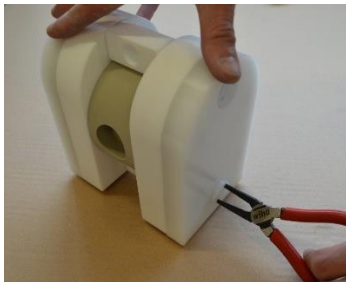

**Fig. 3.5.1 PTFE only**

Using a pair of pliers unscrew the plugs [571] and lift the PE covers [1181].

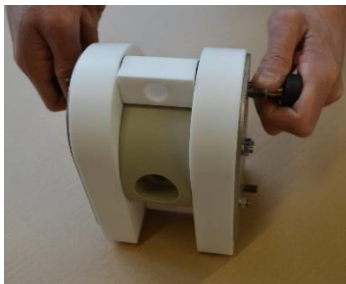

**Fig. 3.5.2**

Unscrew the housing nuts [37] and carefully remove the pin screws [14].



**Fig. 3.5.3**

Lay down the pump on one side and lift one of the housings [11].



**Fig. 3.5.4**

Lift the loose manifolds [13] and centre block [12] from the second housing [11].

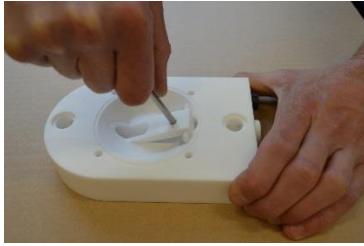

**Fig. 3.5.5**

Screw a pin screw into the hole of the spacer sleeve [19].

### 3. MAINTENANCE

---



**Fig 3.5.6**

Lift and pull out the spacer sleeve [19].



**Fig 3.5.7**

Take out the valve rods [20] and [21],



**Fig 3.5.8**

Unscrew the diaphragms [15] from the air valve [61].



**Fig 3.5.9**

Using pliers remove both circlips [27] from the centre block [12].

**Attention!** While doing this, cover yourself with your other hand, as the circlip easily flips away.

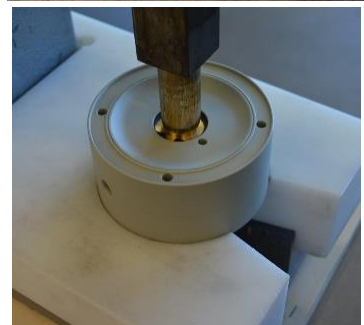

**Fig 3.5.10**

Press out the air valve [61] by means of a pressing device. Be careful not to damage the brass edges of the air valve.

The pump is now completely disassembled. Check all components for wear or damage and replace if necessary.

When air valve is removed from the centre body check the external O-rings (6 x pos. 30) condition and replace if necessary.

# 3. MAINTENANCE

## 3.6. TR9 / TR20 – Assembly of the pump

The assembly procedure is done in the reverse order to the disassembly. Nevertheless there are a few things that you have to remember in order to assemble the pump correctly.



**Fig. 3.6.1**

When putting the air valve [61] into the centre block [12], apply some water or alcohol on the O-rings to provide smooth insertion of the air valve. It is recommended to use a pressing device for this operation.

**NOTE!** When inserting the TR9 / TR20 size air valve, replace the shaft with a screw and a nut to make sure the air valve assembly remains properly fastened.



**Fig. 3.6.2**

When screwing in the diaphragms [15] on the shaft [16], the holes in the diaphragms must align with the holes in the centre block [12]. Sometimes it is necessary to turn the diaphragm back a little bit in order to align the holes.



**Fig. 3.6.3**

When putting in the pin screws [14] take extra care not to damage the diaphragms [15] with the pin screw thread.

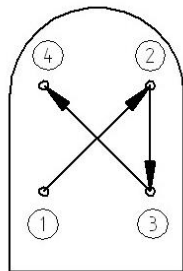

**Fig. 3.6.4**

When fastening the domed nuts, remember to do it according to the tightening procedure and with the appropriate torque.

**NOTE!** After a few weeks of operation retighten the domed nuts with the appropriate torque.

### 3.6.1. Test run



We recommend you to conduct a test run of the pump before installing it in the system, so no liquid gets wasted if the pump leaks or perhaps does not start accordingly to wrong assembly of the pump.

**After a few weeks of operation retighten the nuts with appropriate torque.**

# 3. MAINTENANCE

---

## 3.7. T50-T800 – Disassembly of the pump

The numbers put in brackets, refer to the part numbers in the spare part drawings and spare part lists in chapter 4 "SPARE PARTS".

### 3.7.1. Before the disassembly procedure



Be sure to drain all liquid from the pump. Cleanse or neutralize the pump thoroughly. Disconnect the air supply and then the suction and discharge connections.

### 3.7.2. Disassembly procedure

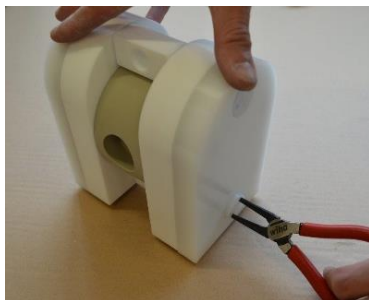

**Fig. 3.7.1 PTFE only**

Using a pair of pliers unscrew the plugs [571] and lift the PE covers [1181].



**Fig. 3.7.2**

Unscrew the housing nuts [37] and carefully remove the pin screws [14].



**Fig. 3.7.3**

Lay down the pump on one side and lift one of the housings [11].



**Fig. 3.7.4**

Lift the loose manifolds [13] and centre block [12] from the second housing [11].

### 3. MAINTENANCE

---



**Fig. 3.7.5**

To remove the spacer sleeve [19], use a plastic rod and a hammer to knock it out.

**NOTE!** Be careful not to deform the spacer sleeve.



**Fig. 3.7.6**

Insert our special tool or pin screw [14] into the orifice in the spacer sleeve [19], rotate it.

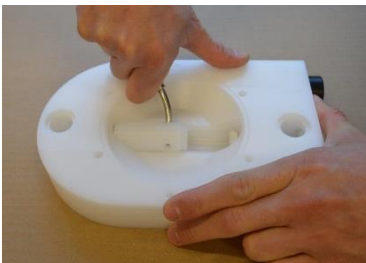

**Fig. 3.7.7**

Pull out the spacer sleeve [19].



**Fig. 3.7.8**

Pull out the lower sleeve [212], valve seat [222] and O-ring [43].



**Fig. 3.7.9**

Pull out the upper sleeve [202] alongside with the valve seat [222], O-ring [43] and the blocking pin [2021].



**Fig. 3.7.10**

Unscrew the diaphragm [15] from one side of the pump.



### 3. MAINTENANCE

---

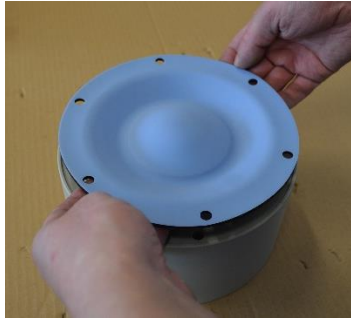

**Fig. 3.7.11**

Take out the second diaphragm [15] along with the shaft [16].

#### a) Circlip mounted air valve – T/TX50, T100 and T800



**Fig. 3.7.12**

Using pliers remove both circlips [27] from the centre block [12].

**Attention!** While doing this, cover yourself with your other hand, as the circlip easily flips away



**Fig. 3.7.13**

Press out the air valve [61] by means of a pressing device. Be careful not to damage the brass edges of the air valve.

#### b) Plate mounted air valve – T/TX100, T/TX200, T/TX400 from s/n 1106

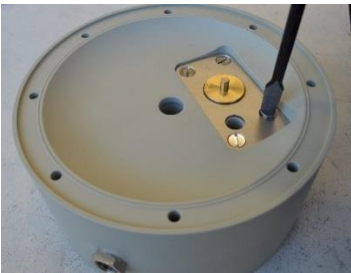

**Fig. 3.7.14**

Unscrew plate screws [2711] from both sides of the centre body [122] and take out the left and right plate [271].



**Fig. 3.7.15**

Press out the air valve [61] by means of a pressing device. Be careful not to damage the brass edges of the air valve.

### 3. MAINTENANCE

---

- c) Threaded air valve – T200 from s/n 0803-... until 1105-... and T400 from s/n 0801-... until 1105-...



**Fig. 3.7.16**

Carefully unscrew both air valve end caps by means of a mounting tool [282].

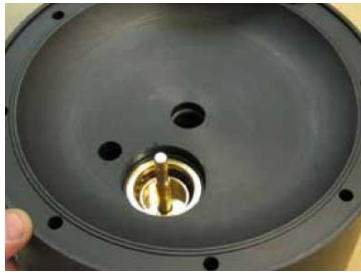

**Fig. 3.7.17**

Push out by hand the air valve shaft and piston.



**Fig. 3.7.18**

To push out the cylinder, use the other side of the mounting tool. Use a pressing device to remove the air valve cylinder from the centre body [123].

The pump is now completely disassembled. Check all components for wear or damage and replace if necessary.

When air valve is removed from the centre body check the external O-rings (6 x pos. 30) condition and replace if necessary.

# 3. MAINTENANCE

## 3.8. T50-T800 – assembly of the pump

The assembly procedure is done in the reverse order to the disassembly. Nevertheless there are a few things that you have to remember in order to assemble the pump correctly.



**Fig. 3.8.1**

When putting the air valve [61] into the centre block [12], apply some water or alcohol on the O-rings to provide smooth insertion of the air valve.

It is recommended to use a pressing device for this operation.



**Fig. 3.8.2**

When there is need to replace the diaphragm pin screw [1652], while screwing it into the diaphragm [15] make sure the pin screw goes all the way.



**Fig. 3.8.3**

When screwing in the diaphragms [15] on the shaft [16], the holes in the diaphragms must align with the holes in the centre block [12]. Sometimes it is necessary to turn the diaphragm back a little bit in order to align the holes.

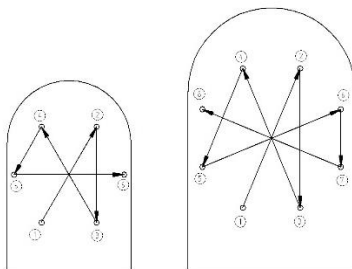

**Fig. 3.8.4**

When fastening the domed nuts, remember to do it according to the tightening procedure and with the appropriate torque.

**NOTE!** After a few weeks of operation retighten the domed nuts with the appropriate torque.

### 3.8.1. Test run



We recommend you to conduct a test run of the pump before installing it in the system, so no liquid gets wasted if the pump leaks or perhaps does not start accordingly to wrong assembly of the pump.

**After a few weeks of operation retighten the nuts with appropriate torque.**



## 4. OPTIONS

### 4. OPTIONS

#### 4.1. Drum pump – TD...

This solution is ideal if we want the pump to be mobile. It is equipped with a stainless steel carrying handle and a suction tube which is screwed in directly in to the inlet manifold. The standard tube length is 2 meters. You can easily take the pump off a barrel or container and move it to another one.

Available for pump sizes:

- TDR20, TD50 and TD100

**Additional / different parts:**

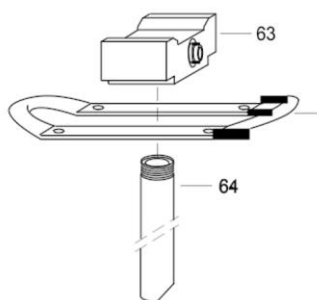

Art. no	Q-ty	Description	Material
6-xxx-63	1	Drum inlet	PE, PTFE
6-xxx-64	1	Pump tube	PP, PTFE
6-xxx-65	1	Handle	AISI 316L



#### 4.2. Twin connections – TT...

Tapflo pumps can be fitted with double inlet/outlet. This allows to have “two pumps in one”. It is used for blending, mixing or recirculation of liquids. Both pump chambers are separated so, the liquid does not mix.

Available for pump sizes:

- TRT9, TRT20, TT50, TT100, TT200 and TT400

**Additional / different parts:**



Art. no	Q-ty	Description	Material
6-xxx-130	2	Twin inlet/outlet	PE, PTFE



## 4. OPTIONS

### 4.3. Filter press pump – TF...

The Tapflo filter press pump is a ready, compact product that can be installed directly on the filter press. The pump is equipped with a booster which amplifies the pressure in a 2:1 ratio. As a result we can achieve up to 16 bar on the discharge of the pump (depending on pump size). As a standard the booster is equipped with a pressure regulator and two manometers. In comparison to a standard pump the TF version is equipped with reinforcement plates and special air valve with PET piston (6-xxx-61-318).

We also recommend to use aluminium centre body (-6A option) instead of standard PP for better durability.

Available for pump sizes:

- TF50, TF100, TF200 and TF400

**Additional / different parts:**

Art. no	Q-ty	Description	Material
6-xxx-1171	1	Long reinforcement plate	AISI 316L
6-xxx-1172	1	Short reinforcement plate	AISI 316L
6-xxx-1175	1	Booster mounting plate	AISI 316L
6-xxx-14	2	Pin screws	AISI 316L
6-xxx-99	1	Booster complete set	-

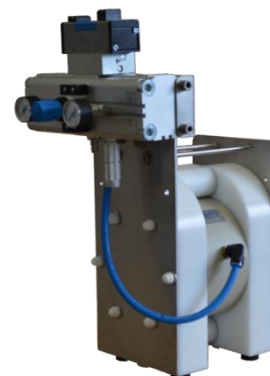

### 4.4. Barrier pump – TB...

With its special construction and control system the barrier pump is perfect when diaphragm rupture has to be immediately detected in order to avoid product leak to the environment and the air distribution system. When rupture is detected the pump is automatically stopped and an alarm can be generated.

Available for pump sizes:

- TRB20, TB50, TB100, TB200 and TB400

**Additional / different parts:**

Art. no	Q-ty	Description	Material
6-xxx-129	2	Spacer	PP, PE, AISI 316L, Aluminium
6-xxx-139	2	Long inlet/outlet	PE, PTFE
6-xxx-149	4/6/8 *	Pin screw	AISI 304
6-xxx-151	2	Diaphragm – air side	EPDM, PTFE, NBR
6-xxx-152	2	Diaphragm – liquid side	EPDM, PTFE, NBR
6-xxx-153	4/6**	O-ring	FKM, NBR, EPDM
6-xxx-159	2***	Diaphragm spacer	PP, PE, AISI 316L, Aluminium
6-xxx-169	1	Diaphragm shaft	AISI 316L
6-xxx-339	2	Spacer plug	PE

\*4 for TRB20, 6 for TB50 and TB100, 8 for TB200 and TB400

\*\* 4 for TRB20 and TB50; 6 for TB100, TB200 and TB400

\*\*Only TB200 and TB400



## 4. OPTIONS

### 4.5. Pump with built-on dampener – TK ...

If you are looking for an effective way to eliminate pressure variations on the pump discharge and you have limited space in your installation, the built-on dampener is an ideal solution. It provides all the advantages of using a standard Tapflo DT dampener but is a compact solution. The dampener housing is also the pump manifold so you do not have to worry about connecting the dampener to the pump. This solution does not affect the pump flow nor the dampening effect.

Available for pump sizes:

- TRK20, TK50, TK100

**Additional / different parts:**

Art. no	Q-ty	Description	Material
DTK-xxx	1	Built-on dampener assembly	-
6-xx1-112	1	Dampener housing / pump outlet	PE, PTFE
6-xx1-12	1	Dampener centre body	PP
6-xx0-15	1	Dampener diaphragm	EPDM, PTFE, NBR, PTFE 1705b
6-xx0-1652	1	Dampener grub screw	St45H
6-xx0-37	8/12****	Dampener nut	AISI 316
6-xx0-38	8/12****	Dampener washer	AISI 316
6-xx0-36	3/5*	Dampener PE seal	PE
6-xx0-47	3/5/10**	Dampener O-ring	NBR, EPDM, FKM
6-xx1-16	1	Dampener shaft	AISI 316L
6-xx1-14	4/6***	Dampener pin screw	AISI 316
6-xx1-25	1	Dampener muffler	PPM-F
6-xx1-27	1	Dampener blocking ring	PE

\*3 for TRK20, 5 for TK50 and TK100

\*\*3 for TRK20, 5 for TK50, 10 for TK100

\*\*\*4 for TRK20, 6 for TK50 and TK100

\*\*\*\* 8 for TRK20, 12 for TK50 and TK100



### 4.6. Pump with integrated flanges – T... -3D/-3A

Pumps with integrated flanges are a robust and solid design. When there is a risk of transferring of vibration from the installation to the pump, the solid manifolds provide better stability and sealing for the pump. Using this solution we can connect the pump to the installation by a flange (DIN, ANSI) or through a BSP thread.

Available for pump sizes:

- T50, T100, T200, T400



## 4. OPTIONS

---

Additional / different parts:

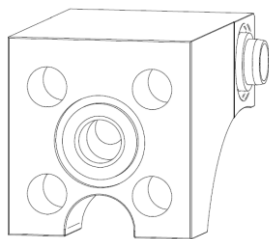

Art. no	Q-ty	Description	Material
6-xxx-725-2	2	DIN Integrated flange	PE, PTFE
6-xxx-725-9	2	ANSI integrated flange	PE, PTFE
6-xxx-131	8	Threaded insert	PET



# 5. SPARE PARTS

## 5.2. TR9 and TR20 – Spare parts list

Pos.	Q-ty	Description	Material	KIT LIQ	KIT AIR
11	2	Housing	PE or PTFE		
12	1	Centre block	PP		
13	2	In/Outlet	PE or PTFE		
14	4	Pin screw	A4-80		
15	2	Diaphragm	EPDM*, PTFE, NBR* or FKM	x	
16	1	Diaphragm shaft (part of air valve assembly)	AISI 316L		
17	4	Rubber foot	NBR		
18	4	O-ring set (in/outlet)	PTFE/EPDM, EPDM, FKM, NBR* or FEP/FKM***	x	x
19	2	Spacer sleeve	PE or PTFE		
20	2	Lower rod	PTFE	x	
21	2	Upper rod	PTFE	x	
22	2	Pin	PTFE	x	
25	1	Muffler	PP		x
27	2	Circlip	Cr3 coated steel		
30	6	O-ring	NBR (standard), EPDM or FKM		
33	2	Plug	PE or PTFE		
37	8	Nut	A4-70		
38	8	Washer	A4-70		
57	8	Nut cover	PP		
61	1	Air valve complete	Body: brass (standard), AISI 316L or PET, O-rings: NBR (standard), EPDM or FKM		x

Stainless steel reinforcement (std. on ATEX PTFE)			
117	2	Reinforcement plate	AISI 316L
147	4	Pin screw	A4-80

Stainless steel / PE reinforcement**			
1173	2	Reinforcement plate	AISI 316L
1181	2	Cover	PE
147	4	Pin screw	A4-80
571	4	Plug	PE

Twin connection			
130	2	Twin in/outlet	PE, PTFE

Drum pump*			
63	1	Drum inlet	PE, PTFE
64	1	Pump tube	PP, PTFE
65	1	Handle	AISI 316L

Valve ball version*			
23	4	Valve ball	EPDM, PTFE, NBR, FKM, AISI 316L, PU
191	2	Spacer sleeve	PE, PTFE
201	2	Upper sleeve	PE, PTFE
211	2	Lower sleeve	PE, PTFE
221	4	Valve ball stop	PE, PTFE
43	4	OP-ring	PTFE

Built-on dampener*			
DTK 9/20	1	Dampener for TK pump version	PE, PTFE

Flange connections*			
70	2	Flange pipe (thread)	PE, PTFE
71	2	ANSI flange ring	PP, PTFE, AISI316L
73	2	DIN flange ring	PP, PTFE, AISI316L
712	2	JIS flange ring	PP, PTFE, AISI316L
721	2	Integrated manifold with loose flange	PP, PTFE

External air supply			
36	2	Centerblock sealing	PE
47	2	O-ring	NBR (std.), EPDM, FKM
124	1	Centerblock	PP
161	1	Shaft	AISI 316L

Double diaphragm system*			
129	1	Set of spacers (right + left)	PP
139	2	In/outlet	PE, PTFE
149	4	Pin screw for PE pump	AISI 316L
1497		Pin screw for PTFE pump	
151	2	Air side diaphragm	EPDM*, PTFE, NBR* or FKM
152	2	Liquid side diaphragm	EPDM*, PTFE, NBR* or FKM
153	4	Diaphragm O-ring	EPDM, FKM, NBR
169	1	Diaphragm shaft (part of air valve assembly)	AISI 316L
339	2	Spacer plug	PP
619	1	Air valve complete	See pos.61

\* = TR20 only

\*\* = Standard on PTFE pumps from serial number 1012 ....

\*\*\* = Standard in pumps with PTFE diaphragms from serial No 1301 .... (TR20) and from 1405 .... (TR9)

FEP/FKM O-rings do not fit on older in/outlets (pos. 13). Older pumps have PTFE/EPDM as standard.

# 5. SPARE PARTS

## 5.3. T50-T100 – Spare parts drawing

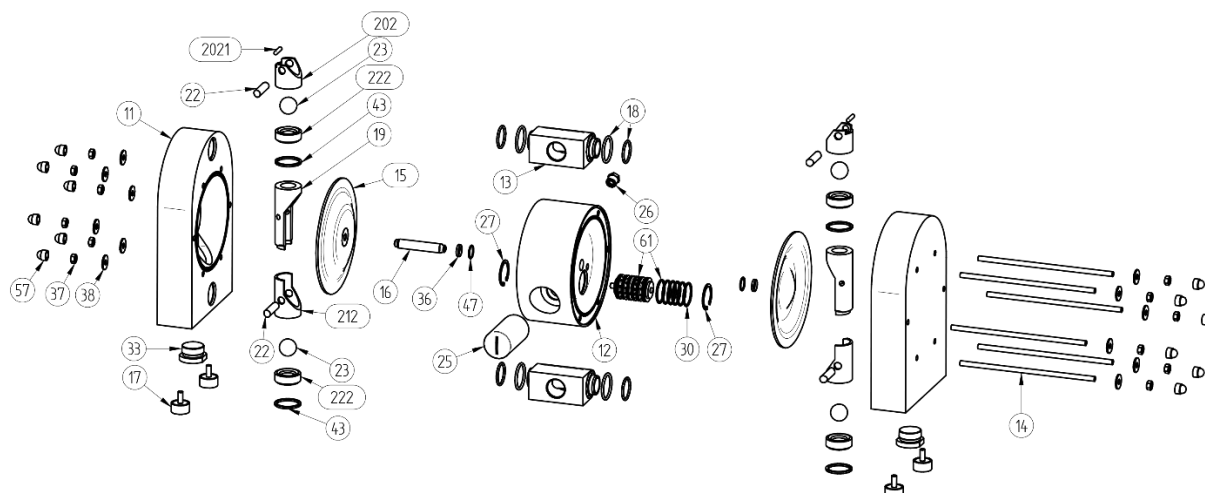

## 5.4. T50-T100 – Spare parts list

Pos.	Q-ty	Description	Material	KIT LIQ	KIT AIR	KIT VAL
11	2	Housing	PE, PTFE			
12	1	Centre block	PP			
13	2	In/Outlet	PE, PTFE			
14	6	Pin screw	A4-80			
15	2	Diaphragm	EPDM, PTFE, NBR, FKM*	x		
16	1	Diaphragm shaft	AISI 316L		x	
17	4	Rubber foot	NBR			
18	4	O-ring set (in/outlet)	PTFE/EPDM, EPDM, FKM, NBR, FEP/FKM***	x	x	
19	2	Spacer sleeve	PE, PTFE			x
202	2	Upper sleeve	PE, PTFE, AISI 316L			x
2021	2	Blocking pin	PTFE, PE**			x
212	2	Lower sleeve	PE, PTFE, AISI 316L			x
22	4	Valve ball stop	PE1000, PTFE, PU, AISI 316L			x
222	4	Valve seat	PE1000, PTFE, PU, AISI 316L			x
23	4	Valve ball	EPDM, PTFE, NBR, FKM, AISI 316L, PU or ceramic	x		
25	1	Muffler	PP		x	
26	1	Air intake adapter	Galvanized brass			
27	2	Circlip	Cr3 coated steel			
30	6	O-ring	NBR (standard), EPDM, FKM			
33	2	Plug	PE, PTFE			
36	2	Centerblock seal	PE		x	
37	12	Nut	A4-70			
38	12	Washer	A4-70			
43	4	O-ring (valve seat)	EPDM, PTFE, NBR, FKM	x		
47	2*/4**	O-ring (back up for 36)	NBR (standard), EPDM, FKM		x	
57	12	Nut cover	PP			
61	1	Air valve complete	Body: brass (standard), AISI 316L or PET, O-rings: NBR (standard), EPDM or FKM		x	

\* = T50 only

\*\* = T100 only

\*\*\* = FEP/FKM standard on pumps with PTFE diaphragms from serial No 1106 .... FEP/FKM O-rings do not fit on older in/outlets (pos. 13). Older pumps have PTFE/ EPDM in std.

# 5. SPARE PARTS

## 5.5. T50-T100 – Spare parts - Options

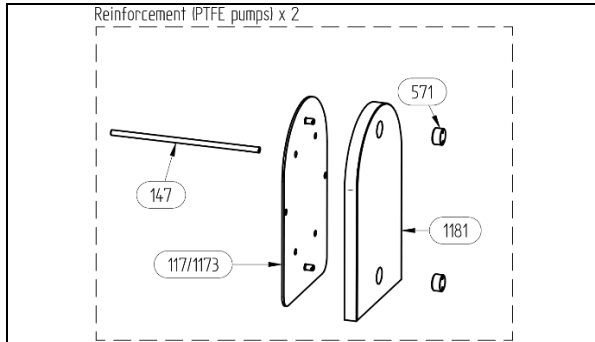

### Stainless steel reinforcement (std. on ATEX PTFE)

117	2	Reinforcement plate	AISI 316L
147	6	Pin screw	A4-80

### Stainless steel / PE reinforcement

1173	2	Reinforcement plate	AISI 316L
1181	2	Cover	PE
147	6	Pin screw	A4-80
571	4*/8**	Plug	PE

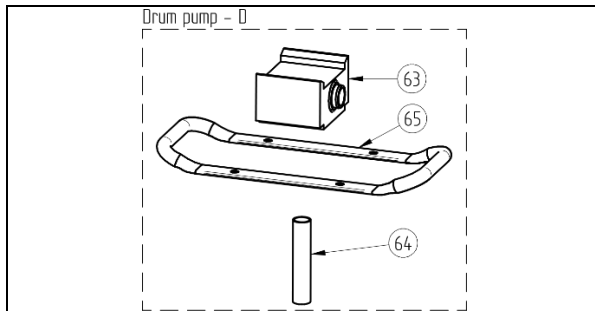

### Drum pump

63	1	Drum pump inlet	PE, PTFE
64	1	Pump tube	PP, PTFE
65	1	Handle	AISI 316L

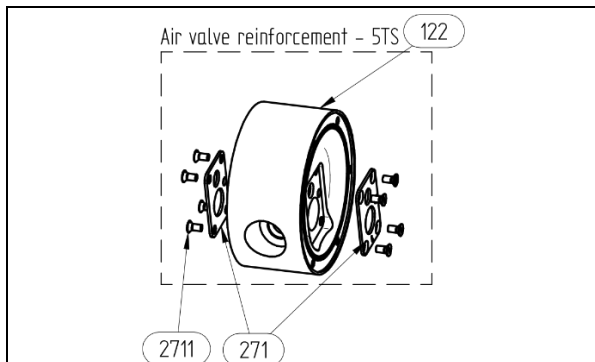

### Plate mounted air valve (std. in TX100 form 1106)

122	1	Centerblock	PP
271	1	Set of 2 plates	AISI 316L
2711	8	Screws	A4-70

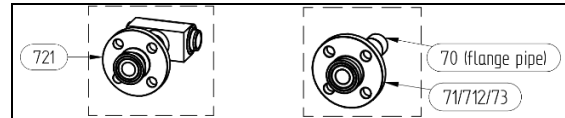

### Flange connections

70	2	Flange pipe (thread)	PE, PTFE
71	2	ANSI flange ring	PP, PTFE, AISI316L
73	2	DIN flange ring	PP, PTFE, AISI316L
712	2	JIS flange ring	PP, PTFE, AISI316L
721	2	Integrated manifold with loose flange	PP, PTFE

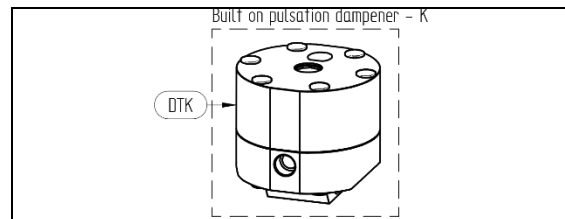

### Built-on dampener

DTK	1	Dampener for TK pump version	PE, PTFE
-----	---	------------------------------	----------



### High lift seats

203	2	Upper sleeve – high lift	PE, PTFE
213	2	Lower sleeve – high lift	PE, PTFE

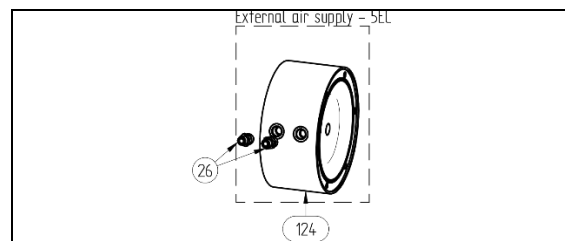

### External air supply

124	1	Centerblock	PP
26	2	Air intake adapter	Brass



### Twin connection

130	2	Twin in/outlet	PE, PTFE
-----	---	----------------	----------



# 5. SPARE PARTS

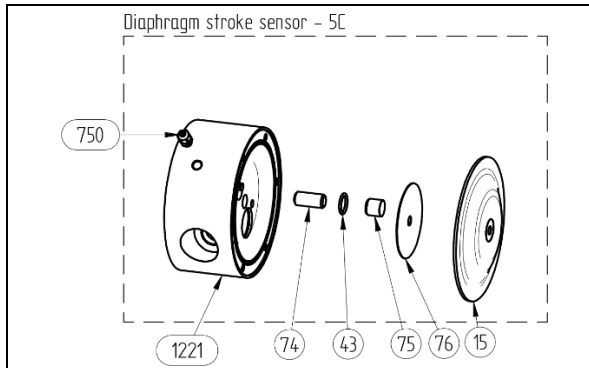

Diaphragm stroke sensor			
121	1	Centerblock for stroke sensor	PP
43	1	O-ring	NBR, FKM, EPDM
74	1	Inductive sensor	CuZn
75	1	Sensor cap	PP
76	1	Sensing plate	AISI 316L
750	1	Cable gland	PP

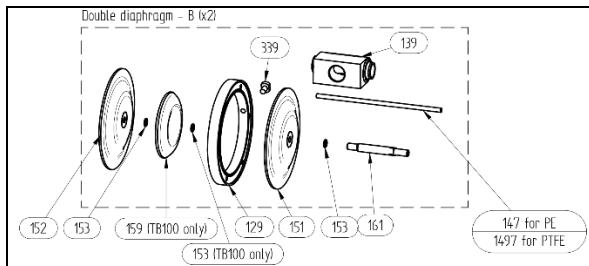

Double diaphragm system			
129	1	Set of spacers (right + left)	PP
139	2	In/outlet	PE, PTFE
149	4	Pin screw for PE pump	A4-80
1497		Pin screw for PTFE pump	
151	2	Air side diaphragm	EPDM, PTFE, NBR or FKM
152	2	Liquid side diaphragm	EPDM, PTFE, NBR or FKM
153	4*/6**	Diaphragm O-ring	EPDM, FKM, NBR
159	2**	Diaphragm spacer	
169	1	Diaphragm shaft	AISI 316L
339	2	Spacer plug	PP

\* = T50 only

\*\* = T100 only

\*\*\* = For Festo booster 2 x 1172, for SMC and Metal Work 1 x 1171 and 1 x 1172

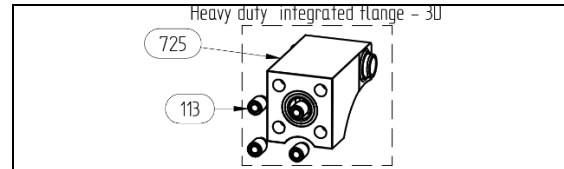

Integrated flange			
725-2	2	DIN integrated flange	PE, PTFE
725-9	2	ANSI integrated flange	PE, PTFE
113	8	Threaded inserts	PET

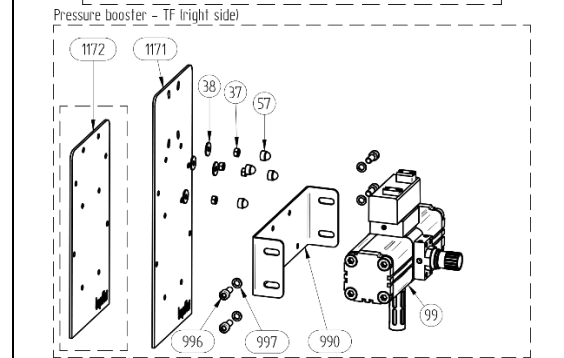
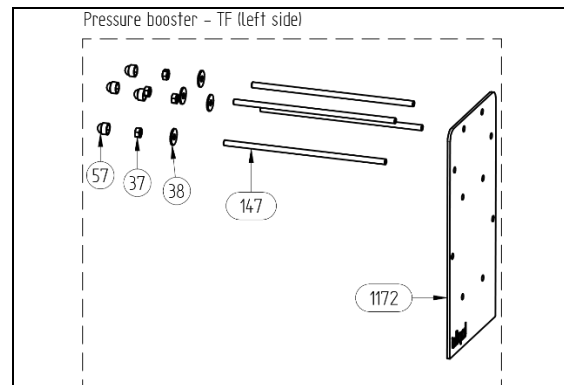

Pump with pressure booster			
99	1	Booster	-
990	1	Booster mounting plate	AISI 304
996	4	Booster mounting screw	A4-70
997	4	Booster mounting washer	A4-80
1171	1/0***	Reinforcement plate	AISI 304
1172	1/2***	Reinforcement plate	AISI 304
37	6	Additional nuts	AISI 304
38	6	Additional washers	AISI 304
57	4	Additional nut covers	PP
147	2	Additional pin screws	A4-80

# 5. SPARE PARTS

## 5.6. T200-T400 – Spare parts drawing

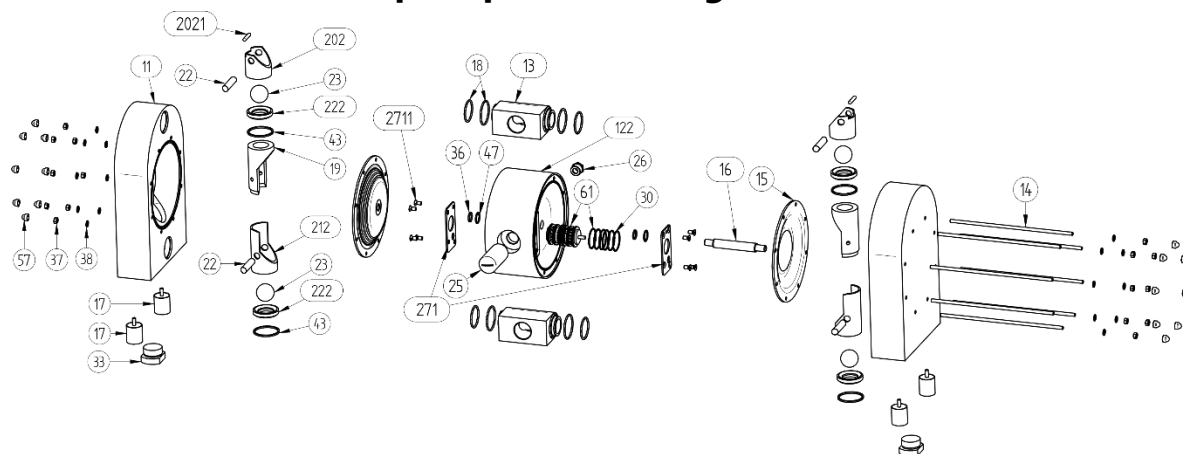

## 5.7. T200-T400 – Spare parts list

Pos.	Q-ty	Description	Material	KIT LIQ	KIT AIR	KIT VAL
11	2	Housing	PE, PTFE			
122	1	Centre block	PP			
13	2	In/Outlet	PE, PTFE			
14	8	Pin screw	AISI 316			
15	2	Diaphragm	EPDM, PTFE, NBR, PTFE 1705b	x		
16	1	Diaphragm shaft	AISI 316		x	
17	4	Rubber foot	NBR			
18	4	O-ring set (in/outlet)	PTFE/EPDM, EPDM, FKM, NBR, FEP/FKM**	x	x	
19	2	Spacer sleeve	PE, PTFE			x
202	2	Upper sleeve	PE, PTFE, AISI 316			x
2021	2	Blocking pin	PTFE, PE			x
212	2	Lower sleeve	PE, PTFE, AISI 316			x
22	4	Valve ball stop	PE1000, PTFE			x
222	4	Valve seat	PE1000, PTFE, PU, AISI 316, PTFE 1635			x
23	4	Valve ball	EPDM, PTFE, NBR, FKM, AISI 316, PU or ceramic	x		
25	1	Muffler	PP		x	
26	1	Air intake adapter	Galvanized brass			
271	1	Set of 2 plates	AISI 316			
2711	8	Screw	AISI 316			
30	6	O-ring	NBR (standard), EPDM, FKM			
33	2	Plug	PE, PTFE			
36	2	Centerblock seal	PE		x	
37	16	Nut	AISI 304			
38	16	Washer	AISI 304			
43	4	O-ring (valve seat)	EPDM, PTFE, NBR, FKM	x		
47	2	O-ring (back up for 36)	NBR (standard), EPDM, FKM		x	
57	16	Nut cover	PP			
61	1	Air valve complete	Body: brass (standard), AISI 316 or PET, O-rings: NBR (standard), EPDM or FKM		x	

\* = T200 from s/n 0803... to 1105... and T400 from 0801.... to 1105....

\*\* = FEP/FKM standard on pumps with PTFE diaphragms from serial No 1106 .... FEP/FKM O-rings do not fit on older in/outlets (pos. 13). Older pumps have PTFE/ EPDM in std.

# 5. SPARE PARTS

## 5.8. T200-T400 – Spare parts - Options

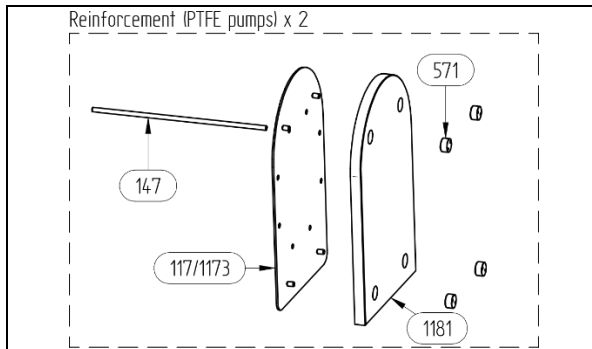

Stainless steel reinforcement (std. on ATEX PTFE)			
117	2	Reinforcement plate	AISI 316L
147	8	Pin screw	A4-80
Stainless steel / PE reinforcement			
1173	2	Reinforcement plate	AISI 316L
1181	2	Cover	PE
147	8	Pin screw	A4-80
571	4	Plug	PE

Twin connection			
130	2	Twin in/outlet	PE, PTFE

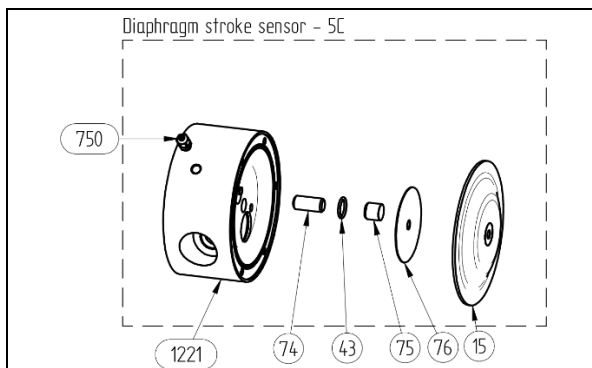

Diaphragm stroke sensor			
1221	1	Centre block for stroke sensor	PP
43	1	O-ring	NBR, FKM, EPDM
74	1	Inductive sensor	CuZn
75	1	Sensor cap	PP
76	1	Sensing plate	AISI 316L
750	1	Cable gland	PP

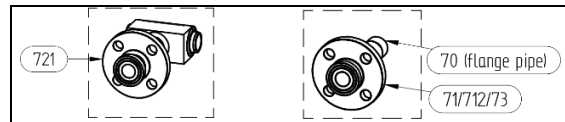

Flange connections			
70	2	Flange pipe (thread)	PE, PTFE
71	2	ANSI flange ring	PP, PTFE, AISI316L
73	2	DIN flange ring	PP, PTFE, AISI316L
712	2	JIS flange ring	PP, PTFE, AISI316L
721	2	Integrated manifold with loose flange	PP, PTFE

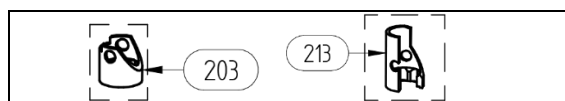

High lift seats			
203	2	Upper sleeve – high lift	PE, PTFE
213	2	Lower sleeve – high lift	PE, PTFE

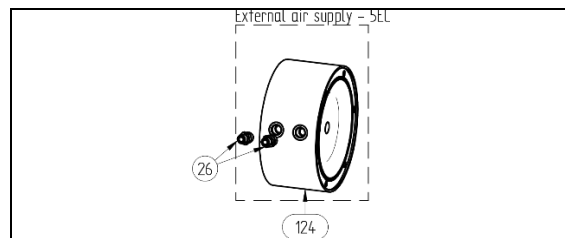

External air supply			
124	1	Centre block	PP
26	2	Air intake adapter	Brass

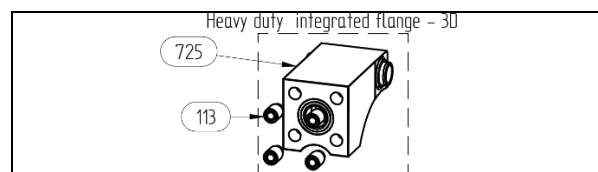

Integrated flange			
725-2	2	DIN integrated flange	PE, PTFE
725-9	2	ANSI integrated flange	PE, PTFE
113	8	Threaded inserts	PET

# 5. SPARE PARTS

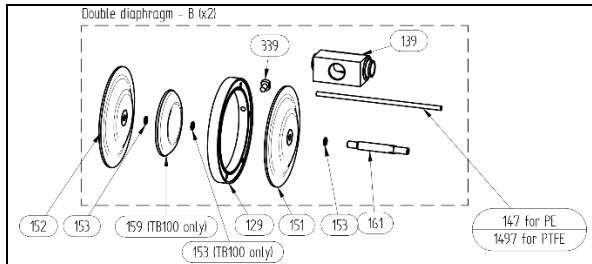

Double diaphragm system			
129	1	Set of spacers (right + left)	PP
139	2	In/outlet	PE, PTFE
149	8	Pin screw for PE pump	A4-80
1497		Pin screw for PTFE pump	
151	2	Air side diaphragm	EPDM, PTFE, NBR or FKM
152	2	Liquid side diaphragm	EPDM, PTFE, NBR or FKM
153	6	Diaphragm O-ring	EPDM, FKM, NBR
159	2	Diaphragm spacer	
169	1	Diaphragm shaft	AISI 316L
339	2	Spacer plug	PP

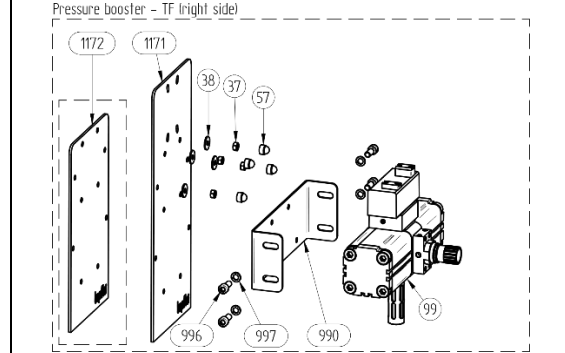
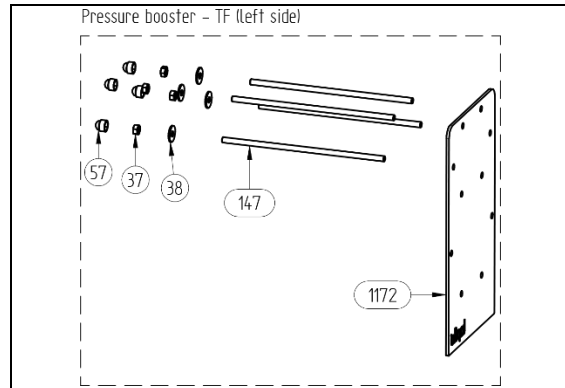

Pump with pressure booster			
99	1	Booster	-
990	1	Booster mounting plate	AISI 304
996	4	Booster mounting screw	A4-70
997	4	Booster mounting washer	A4-80
1171	1/0*	Reinforcement plate	AISI 304
1172	1/2*	Reinforcement plate	AISI 304
37	6	Additional nuts	AISI 304
38	6	Additional washers	AISI 304
57	4	Additional nut covers	PP
147	2	Additional pin screws	A4-80

\* = For Festo booster 2 x 1172, for SMC and Metal Work 1 x 1171 and 1 x 1172



## 5. SPARE PARTS

### 5.10. T800 – Spare parts list

Pos.	Q-ty	Description	Material	KIT LIQ	KIT AIR	KIT VAL
11	2	Housing	PE			
12	1	Centre block	PP			
137-2*	2	In/outlet integrated with DIN flange	PE			
137-9	2	In/outlet integrated with ANSI flange	PE			
137-12	2	In/outlet integrated with JIS flange	PE			
14	8	Pin screw	AISI 316			
15	2	Diaphragm	EPDM, PTFE, NBR	x		
16	1	Diaphragm shaft	AISI 316		x	
17	8	Rubber foot	NBR			
18	4	O-ring set (in/outlet)	PTFE/EPDM, EPDM, FKM, NBR,	x	x	
19	2	Spacer sleeve	PE			x
203	2	Upper sleeve	PE, PTFE			x
2021	2	Blocking pin	PE, PTFE			x
213	2	Lower sleeve	PE, PTFE			x
22	4	Valve ball stop	PE1000			x
222	4	Valve seat	PE1000			x
23	4	Valve ball	EPDM, PTFE, NBR, PU	x		
25	1	Muffler	PP		x	
26	1	Air intake adapter	Galvanized brass			
27	1	Circlip	Cr3 coated steel			
30	6	O-ring	NBR (standard), EPDM, FKM			
33	2	Plug	PE, PTFE			
36	2	Centre block seal	PE		x	
37	16	Nut	AISI 304			
38	16	Washer	AISI 304			
43	4	O-ring (valve seat)	EPDM, PTFE, FKM	x		
47	2	O-ring (back up for 36)	NBR (standard), EPDM, FKM		x	
57	16	Nut cover	PP			
61	1	Air valve complete	Body: PET*, brass; Piston: PET*, brass; O-rings: NBR, FKM		x	
721-9	2	In/outlet integrated with ANSI flange	PE			

Diaphragm stroke sensor			
1221	1	Centre block for stroke sensor	PP
43	1	O-ring	NBR, FKM, EPDM
74	1	Inductive sensor	CuZn
75	1	Sensor cap	PP
76	1	Sensing plate	AISI 316L
750	1	Cable gland	PP

\* = Standard

## 5. SPARE PARTS

### 5.11. Stocking recommendation

Even at normal operation some details in the pump will be worn. In order to avoid expensive breakdowns we recommend having a few spare parts in stock.

Depending on the severity of the operation and the importance of assuring continuous work we offer three different spare part **KITS** – **KIT LIQ** and **KIT VAL** includes parts on pump wetted side, **KIT AIR** includes parts on the pump air side and that are subject to wear.

#### TR9 and TR20:

	Pos.	Description	Q-ty
<b>KIT LIQ</b>	15	Diaphragm	2
	18	O-ring set in/outlet	4
	20	Lower rod	2
	21	Upper rod	2
	22	Pin	2

	Pos.	Description	Q-ty
<b>KIT AIR</b>	18	O-ring set in/outlet	4
	61	Air valve complete	1
	25	Muffler	1

#### T50, T100, T200, T400 and T800:

	Pos.	Description	Q-ty
<b>KIT AIR</b>	18	O-ring set in/outlet	4
	61	Air valve complete	1
	16	Diaphragm shaft	1
	36	Centre block seal	2
	47	O-ring(back up for 36)	2/4*
	25	Muffler	1

	Pos.	Description	Q-ty
<b>KIT LIQ</b>	15	Diaphragm	2
	18	O-ring set in/outlet	4
	23	Valve ball	4
	43	O-ring (valve seat)	4

	Pos.	Description	Q-ty
<b>KIT VAL</b>	19	Spacer sleeve	2
	2021	Blocking pin	2
	202	Upper sleeve	2
	212	Lower sleeve	2
	222	Valve seat	4
	22	Valve ball stop	4

\* For T100 pump

# 5. SPARE PARTS

## 5.12. How to order parts

When ordering spare parts for Tapflo pumps, please let us know what is the **model number** and **serial number** from the pump centre body or housing. Then just indicate the part numbers from the spare parts list and quantity of each item.

## 5.13. Pump code

The model number on the pump and on the front page of this instruction manual tells the pump size and materials of the pump.

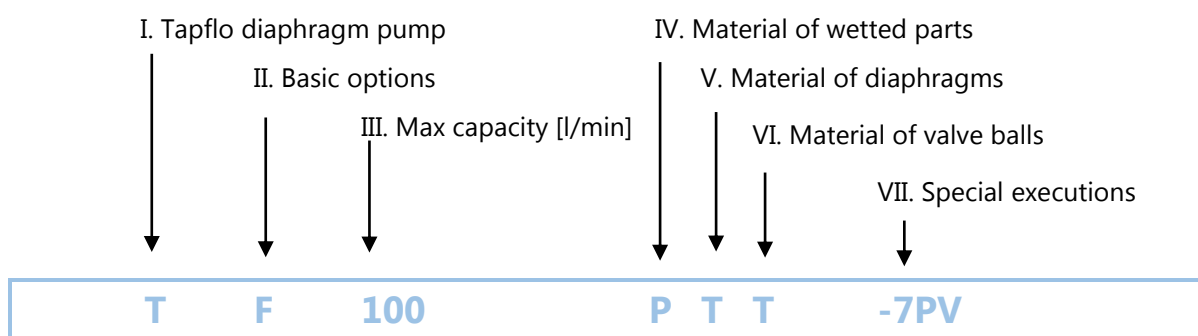

### I. T = Tapflo diaphragm pump

### II. Basic options:

- B = Backup diaphragm pump
- D = Drum pump
- F = Filter-press pump
- K = Pump with built-on dampener (TR20 – T100)
- L = Draining system
- Q = Special sealed pump
- R = Rod valve pump (instead of balls)
- T = Twin inlet/outlet pump
- V = AISI316 valve seats / spacer
- X = ATEX approved, group II, cat. 2
- Y = High lift valve seats
- Z = Semiconductor industry pump

### IV. Material of wetted parts:

- P = PE
- T = PTFE
- L = PP

### V. Material of diaphragms:

- E = EPDM
- W = White (food grade) EPDM
- N = NBR (nitrile rubber)
- T = PTFE
- Z = PTFE with white back (food grade)
- B = PTFE TFM 1705b
- V = FKM (TR9 – T50 only)

### VI. Material of valve balls:

- E = EPDM
- N = NBR (nitrile rubber)
- T = PTFE
- S = AISI 316 stainless steel
- U = PU (polyurethane)
- K = Ceramic
- V = FKM
- B = PTFE TFM 1635

Material of rod valves (TR9 and TR20 only):

- T = PTFE

### VII. Special executions:

- 1 = Optional in/outlet material
- 2 = Valve seat insert
- 3 = Optional connection type
- 4 = Backup diaphragm system configuration
- 5 = Other special executions
- 6 = Optional material of centre body
- 7 = Optional material of air valve
- 8 = Optional material of pos. 18 seals
- 9 = Optional material of housing pin screws
- 11 = Housing reinforcement plates
- 13 = Twin in-/outlet options
- 14 = Optional pump feet
- 17 = Plates for pump/dampener assembly



# 6. DATA

## 6. DATA

### 6.1. Capacity curves

The performance curves are based on water at 20°C. Other circumstances might change the performance. See below how the capacity will change at different viscosities and suction lifts.

**Example:**

A flow of 30 litre/minute is desired. The discharge pressure is calculated to 25 mWC. We choose a T50 pump. It requires an air pressure of 6 bar and will consume approximately 0.20 Nm<sup>3</sup> of air per minute.

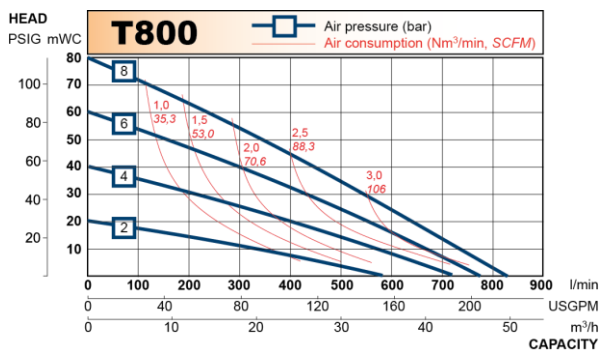
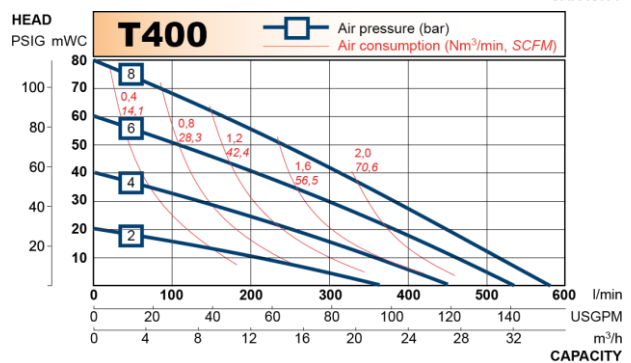
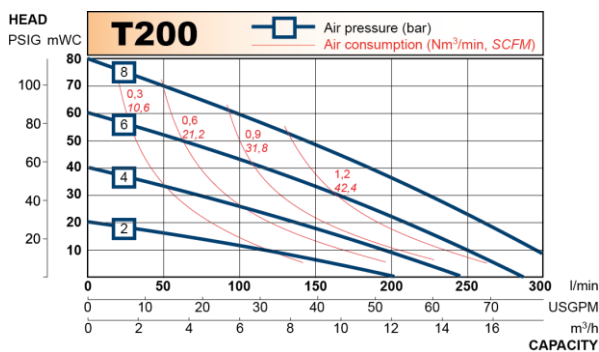
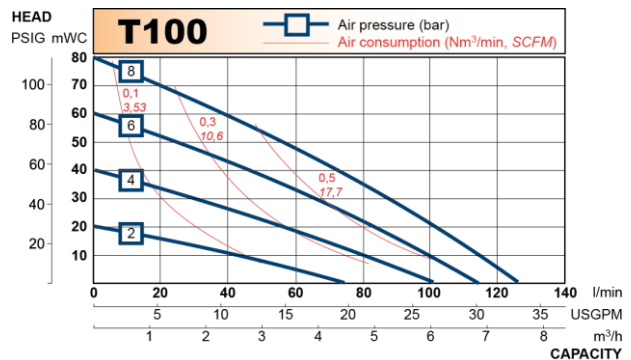
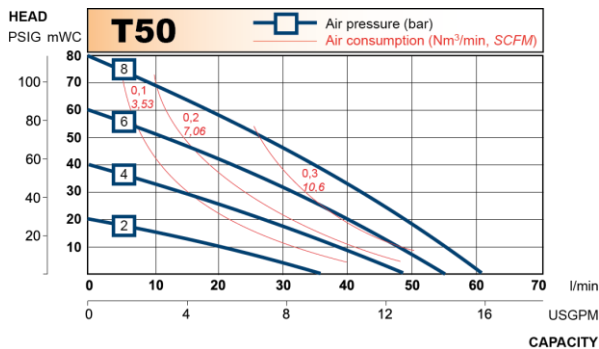
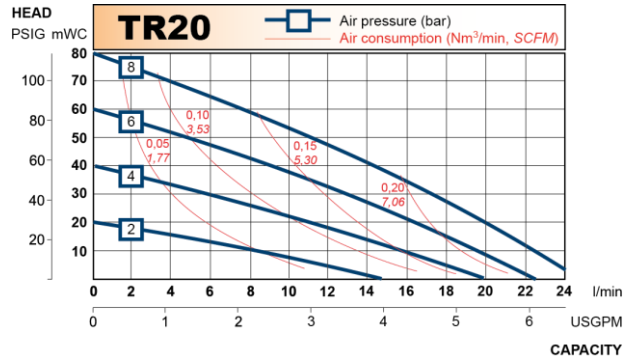
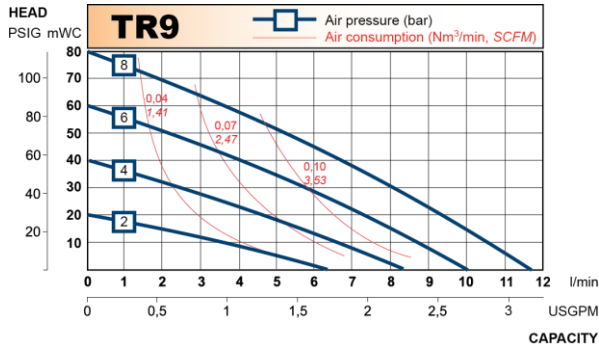

Recommended flow is half of the max flow, e.g. recommended flow for a T50 is 25 l/min.

# 6. DATA

## 6.2. Capacity changes

Capacity changes at different suction lifts

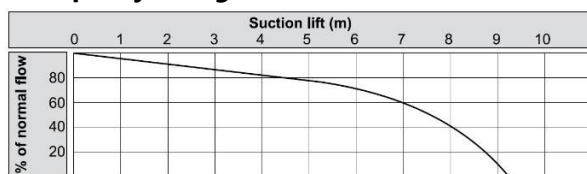

Capacity changes at different viscosities

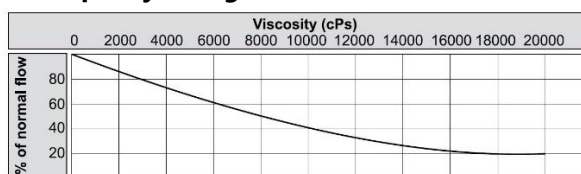

## 6.3. Technical data

TECHNICAL DATA	PUMP SIZE						
	TR9	TR20	T50	T100	T200	T400	T800
Max capacity* [l/min] / [US GPM]	11 / 2.9	24 / 6.3	60 / 15.8	125 / 33	330 / 87	570 / 150	820 / 216
Volume per stroke** [ml] / [cu in]	13 / 0.80	50 / 3.05	87.5 / 5.34	280 / 17.1	933 / 56.9	2300 / 140.3	5125 / 312.7
Max discharge pressure [bar] / [psi]	8 / 116	8 / 116	8 / 116	8 / 116	8 / 116	8 / 116	8 / 116
Max air pressure [bar] / [psi]	8 / 116	8 / 116	8 / 116	8 / 116	8 / 116	8 / 116	8 / 116
Max suction lift dry*** [m] / [Ft]	1.6 / 5.25	2.4 / 7.87	4 / 13	3.5 / 11	4 / 13	4 / 13	5 / 16
Max suction lift wet [m] / [Ft]	8 / 26	8 / 26	9 / 29.5	9 / 29.5	9 / 29.5	9 / 29.5	9 / 29.5
Max size of solids ø in [mm] / [in]	2 / 0.08	3 / 0.12	4 / 0.16	6 / 0.24	10 / 0.39	15 / 0.59	15 / 0.59
Max temp. pump in PE [°C] / [°F]	70 / 158	70 / 158	70 / 158	70 / 158	70 / 158	70 / 158	70 / 158
Max temp. pump in PTFE [°C] / [°F]	100 / 212	100 / 212	100 / 212	100 / 212	100 / 212	100 / 212	-
Weight of pump in PE [kg] / [lb]	0.75 / 1.65	1.6 / 3.53	4.3 / 9.48	10 / 22	25 / 55.12	47 / 103.62	147 / 342
Weight of pump in PTFE [kg] / [lb]	1.35 / 2.98	3.15 / 6.94	9 / 19.84	17 / 38	47 / 103.62	87 / 191.80	-
Weight of drum pump in PE [kg] / [lb]	-	2.4 / 5.29	4.7 / 10.36	10.5 / 23.15	-	-	-
Weight of drum pump in PTFE [kg] / [lb]	-	3.9 / 8.6	9.4 / 20.72	17.5 / 38.58	-	-	-

\* = Recommended flow is half of the max flow, i.e. recommended flow for a T50 is 30 l/min (7.9 US GPM)

\*\* = Based on pumps with EPDM diaphragms. Pumps with PTFE diaphragms have about 15% less volume.

\*\*\* = With stainless steel valve balls, other materials may reduce suction. Please consult us in this matter.

COMPONENT	MATERIAL
Pump housing and all wetted thermoplastic elements	PE, PTFE (apart form T800)
Centre block (not wetted)	PP, PP conductive
Diaphragms	PTFE, PTFE with white back, EPDM, white EPDM, NBR, FKM*
Valve balls	PTFE, EPDM, NBR, AISI 316**, PU, Ceramic**
Rod valves (TR9 and TR20)	PE, PTFE
Air valve	Body: brass (std.), stainless steel AISI 316L or PET O-rings: NBR (std.), EPDM or FKM
O-rings (wetted)	PTFE, EPDM, FKM, FEP/Silicone, FEP/FKM
Housing pin screws	Stainless steel AISI 316
Diaphragm shaft	Stainless steel AISI 316
Drum handle (TD pumps)	Stainless steel AISI 316
Reinforcement plates (TF pumps)	Stainless steel AISI 316

\* = TR9, TR20 and T50 only

\*\* = Not available for T800

# 6. DATA

## 6.4. Dimensions

Dimensions in mm (where other is not indicated)

Dimensions in inch (where other is not indicated)

General dimensions only, ask us for detailed drawings. Changes reserved without notice.

Dim	PUMP SIZE						
	TR9	TR20	T50	T100	T200	T400	T800
A	70 2.76	105 4.13	150 5.91	200 7.87	270 10.63	350 13.78	460 18.11
A2	-	-	150 5.91	300 11.81	300 11.81	404 15.91	-
B	94 3.70	112 4.41	169 6.30	214 8.43	310 12.20	380 14.96	589 23.19
B2	-	-	168 6.61	221 8.70	320 12.60	390 15.35	-
B3	-	-	277 10.91	391 15.39	490 19.29	598 23.54	-
B4	134 5.28	152 5.98	200 7.87	254 10.00	350 13.78	420 16.54	-
C	115 4.53	135 5.31	190 7.48	250 9.84	345 13.58	425 16.73	637 25.08
D	123 4.84	168 6.61	243 9.57	320 12.60	450 17.72	563 22.17	830 32.68
D2	-	175 6.89	250 9.84	325 12.80	-	-	-
D3	-	-	385 15.16	550 21.65	700 27.56	770 30.31	-
D4	-	-	343 13.50	477 18.78	630 24.80	690 27.17	-
E	92 3.62	132 5.20	190 7.48	252 9.92	345 13.58	440 17.32	650 25.59
E2	-	147 5.79	210 8.27	280 11.02	-	-	-
E3	-	-	250 9.84	333 13.11	467 18.39	588 23.15	-
F	8 0.31	8 0.31	15 0.59	15 0.59	30 1.18	30 1.18	30 1.18
F2	-	15 0.59	21 0.83	21 0.83	-	-	-
G	9 0.35	15 0.59	17 0.67	30 1.18	30 1.18	30 1.18	-
H	10 0.39	15 0.59	16 0.63	30 1.18	30 1.18	30 1.18	-
I	12 0.47	15 0.59	20 0.79	28 1.10	38 1.50	48 1.89	80 3.15
J	¼" ¼	3/8" 3/8	½" ½	1" 1	1 ½" 1 ½	2" 2	3" 3
K	M4x20 M4	M4x20 M4	M8x25 M8	M8x25 M8	M8x25 M8	M8x25 M8	M8x25 M8
L	1/8" 1/8	1/8" 1/8	¼" ¼	¼" ¼	½" ½	½" ½	½" 1/2
M	15 0.59	17 0.67	25 0.98	38 1.50	54 2.13	70 2.76	95 3.74
N	58 2.28	81 3.19	115 4.53	154 6.06	211 8.31	268 10.55	410 16.14
P	35 1.38	52 2.05	80 3.15	105 4.13	143 5.63	183 7.20	238 9.37
R	0° 0°	0° 0°	15° 15°	15° 15°	0° 0°	0° 0°	0° 0°
S	13 0.51	15 0.59	21 0.83	27 1.06	35 1.38	42 1.65	-
ØT	-	20 0.79	33 1.30	33 1.30	-	-	-
U	-	1270* 50.00*	1270* 50.00*	1270* 50.00*	-	-	-
V	-	285 11.22	360 14.17	400 15.57	-	-	-

Standard PE pumps

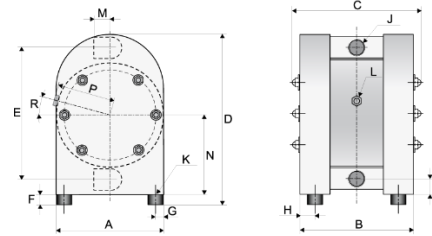

Standard PTFE pumps

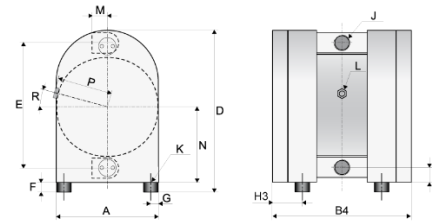

Drum pumps TD

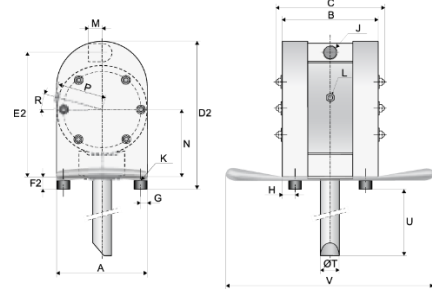

Twin pumps TT

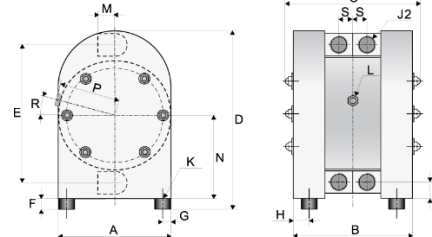

Filterpress pumps TF

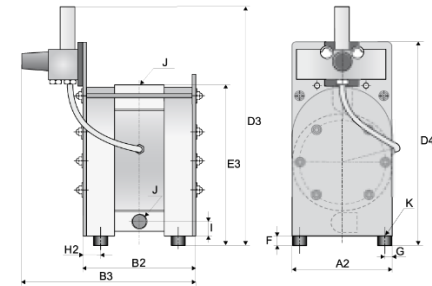

Changes reserved without notice

\* = Any length up to 2000 mm (79") upon request

# 6. DATA

Dim	PUMP SIZE						
	Integrated flanges				Built-on dampener		
	T50	T100	T200	T400	TR20	T50	T100
B	162	216	314	382	112,5	162	216
	6.38	8.50	12.36	15.04	4.43	6.38	8.50
C	185	252	352	427	134	185	252
	7.28	9.92	13.86	16.81	5.28	7.28	9.92
D	244	320	450	564	251	350	461
	9.61	12.60	17.72	22.20	9.88	13.78	18.15
E	140	204	282	372	158	223	299,5
	5.51	8.03	11.10	14.65	6.22	8.78	11.79
F	15	15	30	30	8	15	15
	0.59	0.59	1.18	1.18	0.31	0.59	0.59
G	116	140	210	290	75	116	140
	4.57	5.51	8.27	11.42	2.95	4.57	5.51
H	130	156	254	322	82,5	130	156
	5.12	6.14	10.00	12.68	3.25	5.12	6.14
I	60	67	99,5	112	23	35	43
	2.36	2.64	3.92	4.41	0.91	1.38	1.69
J	½"	1"	1½"	2"	3/8"	½"	1"
	½	1	1 ½	2	3/8	½	1
K	30	30	40	40	15	30	30
	1.18	1.18	1.57	1.57	0.59	1.18	1.18
L	¼"	¼"	½"	½"	1/8"	¼"	¼"
	¼	¼	½	½	1/8	¼	¼
M	100	135	150	175	17	25	38
	3.94	5.31	5.91	6.89	0.67	0.98	1.50
M2	-	-	-	-	53,5	77,5	101,5
	-	-	-	-	2.11	3.05	4.00
N	151	197	241	298	89	151	196,5
	5.94	7.76	9.49	11.73	3.50	5.94	7.74
P	180	240	341	389	134	172	236
	7.09	9.45	13.43	15.31	5.28	6.77	9.29
R	15°	15°	0°	0°	0°	15°	15°
	-	-	-	-	-	-	-
S	65	85	110	125	-	-	-
	2,56	3,35	4,33	4,92	-	-	-
T	M12	M12	M16	M16	-	-	-
	M12	M12	M16	M16	-	-	-
U	30	30	45	45	-	-	-
	1.18	1.18	1.77	1.77	-	-	-

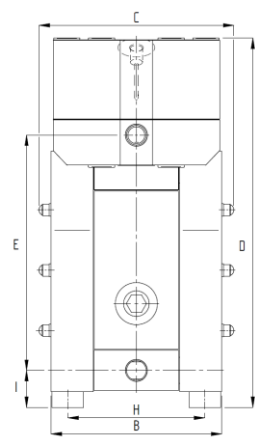
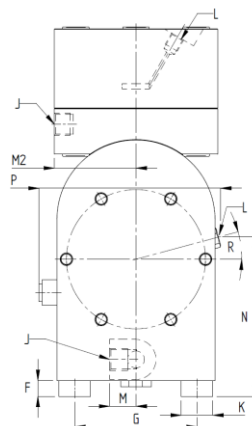
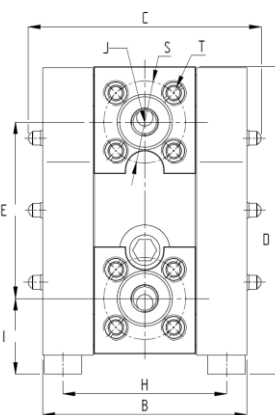
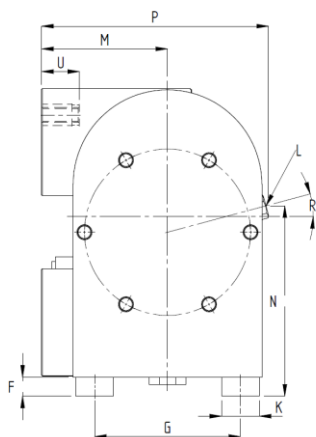

## 6. DATA

### 6.5. Tightening torques

The following tightening torques are recommended.

PUMP SIZE	MOUNTING TORQUE [Nm]
TR9	4
TR20	5,5
T50	8
T100	16
T200	20
T400	23
T800	30

### 6.6. Permitted loads on manifolds

We recommend not to exceed the following loads and forces reacting on the manifolds.

TR9		
Direction	Load [N] (inlet/outlet)	Moment of force (inlet/outlet) [Nm]
X	20	3,5
Y	20	3,5
Z	20	3,5

T400		
Direction	Load [N] (inlet/outlet)	Moment of force (inlet/outlet) [Nm]
X	56	9,6
Y	56	9,6
Z	56	9,6

TR20		
Direction	Load [N] (inlet/outlet)	Moment of force (inlet/outlet) [Nm]
X	27	4,2
Y	27	4,2
Z	27	4,2

T800		
Direction	Load [N] (inlet/outlet)	Moment of force (inlet/outlet) [Nm]
X	83	11
Y	83	11
Z	83	11

T50		
Direction	Load [N] (inlet/outlet)	Moment of force (inlet/outlet) [Nm]
X	31	5,3
Y	31	5,3
Z	31	5,3

T100		
Direction	Load [N] (inlet/outlet)	Moment of force (inlet/outlet) [Nm]
X	35	6,1
Y	35	6,1
Z	35	6,1

T200		
Direction	Load [N] (inlet/outlet)	Moment of force (inlet/outlet) [Nm]
X	43	7,4
Y	43	7,4
Z	43	7,4

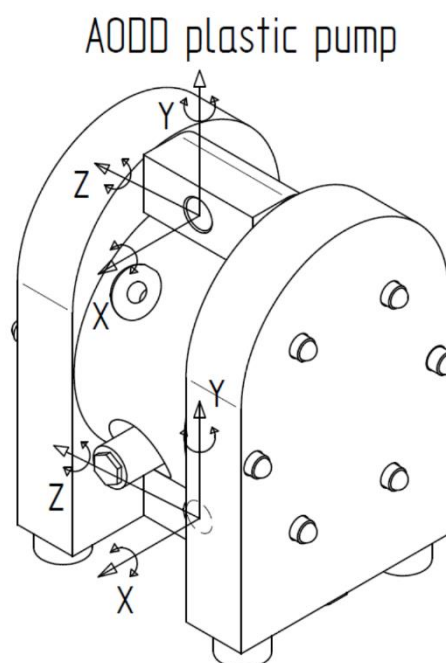



# 7. WARRANTY

---

## 7.2. Returning parts

When returning parts to Tapflo please follow this procedure:

- Consult Tapflo for shipping instructions.
- Cleanse or neutralize and rinse the part/pump. Make sure the part/pump is completely empty from liquid.
- Pack the return articles carefully to prevent any damage during transportation.

***Goods will not be accepted unless the above procedure has been complied with.***

## 7.3. Warranty

Tapflo warrants products under conditions as stated below for a period of not more than 5 years from installation and not more than 6 years from date of manufacturing.

1. The following terms and conditions apply to the sale of machinery, components and related services and products, of Tapflo (hereinafter "the products").
2. Tapflo (the manufacturer) warrants that:
  - a. its products are free of defects in material, design and workmanship at the time of original purchase;
  - b. its products will function in accordance with Tapflo operative manuals; Tapflo does not guarantee that the product will meet the precise needs of the Customer, except for those purposes set out in any invitation to render documents or other documents specifically made available to Tapflo before entering into this agreement;
  - c. high quality materials are used in the construction of the pumps and that machining and assembly are carried out to the highest standards.

Except as expressly stated above, Tapflo makes no warranties, express or implied, concerning the products, including all warranties of fitness for a particular purpose.

3. This warranty shall not be applicable in circumstances other than defects in material, design, and workmanship. In particular warranty shall not cover the following:
  - a. Periodic checks, maintenance, repair and replacement of parts due to normal wear and tear (seals, O-rings, rubber items, diaphragms, air valves etc.);
  - b. Damage to the product resulting from:
    - b.1. Tampering with, abuse or misuse, including but not limited to failure to use the product for its normal purposes as stated at the time of purchase or in accordance with Tapflo instructions for use and maintenance of the product, or the installation or improper ventilation or use of the product in a manner inconsistent with the technical or safety standard in force;
    - b.2. Repairs performed by non-skilled personnel or use of non-original Tapflo parts;

## 7. WARRANTY

---

- b.3. Accidents or any cause beyond the control of Tapflo, including but not limited to lightning, water, fire, earthquake, and public disturbances, etc.;
4. The warrantee shall cover the replacement or repairing of any parts, which is documented faulty due to construction or assembling, with new or repaired parts free of charges delivered by Tapflo. Parts subjected to normal tear and wear shall not be covered by the warranty. Tapflo shall decide as to whether the defective or faulty part shall be replaced or repaired.
  5. The warrantee of the products shall be valid for a period in accordance to the current law from the date of delivery, under the condition that notice of the alleged defect to the products or parts thereof be given to Tapflo in written within the mandatory term of 8 days from the discovery. Repair or replacement under the terms of this warranty shall not give a right to an extension to, or a new commencement of, the period of warranty.
  6. Repair or replacement under the terms of this warranty shall not give a right to an extension to, or a new commencement of, the period of warranty. Repair or replacement under the terms of this warranty may be fulfilled with functionally equivalent reconditioned units. Tapflo qualified personnel shall be solely entitled to carry out repair or replacement of faulty parts after careful examination of the pump. Replaced faulty parts or components will become the property of Tapflo.
  7. The products are built in accordance with standard CE normative and are tested (where applicable) by Tapflo. Approval and tests by other control authority are for the customer's account. The products shall not be considered defective in materials, design or workmanship if they need to be adapted, changed or adjusted to conform to national or local technical or safety standards in force in any country other than that for which the unit was originally designed and manufactured. This warranty shall not reimburse such adaptations, changes or adjustments, or attempt to do so, whether properly performed or not, nor any damage resulting from them, nor any adaptation, change or adjustments to upgrade the products from their normal purpose as described in the products operative manual without the prior written consent of Tapflo.
  8. Installation, including electric and other connections to utility mains according to Tapflo drawings, is for the cost and responsibility of the customer, unless otherwise agreed in writing.
  9. Tapflo will not be liable on any claim, whether in contract, tort, or otherwise, for any indirect, special, incidental, or consequential damages, caused to the customer or to third parties, including loss of profits, arising by any possible infringement of par. 3 above or by the customer or third parties being in the impossibility of using the products.

Steady the above, Tapflo liability to the customer or third parties from any claim, whether in contract, tort, or otherwise, shall be limited to the total amount paid by the customer for the product that caused the damages.



## Sweden

Filaregatan 4 | S-442 34 Kungälv

Tel: +46 303 63390

Fax: +46 303 19916

E-mail addresses:

Commercial questions: sales@tapflo.com

Orders: order@tapflo.com

Tech support: support@tapflo.com

## Tapflo products and services are available in 75 countries on 6 continents.

Tapflo is represented worldwide by own Tapflo Group Companies and carefully selected distributors assuring highest Tapflo service quality for our customers' convenience.

AUSTRALIA | AUSTRIA | AZERBAIJAN | BAHRAIN | BELARUS | BELGIUM | BOSNIA & HERZEGOVINA | BRAZIL | BULGARIA | CANADA | CHILE | CHINA | COLOMBIA | CROATIA | CZECH REPUBLIC | DENMARK | ECUADOR | EGYPT | ESTONIA | FINLAND | FRANCE | GREECE | GEORGIA | GERMANY | HONG-KONG | HUNGARY | ICELAND | INDIA | INDONESIA | IRAN | IRELAND | ISRAEL | ITALY | JAPAN | JORDAN | KAZAKHSTAN | KUWAIT | LATVIA | LIBYA | LITHUANIA | MACEDONIA | MALAYSIA | MEXICO | MONTENEGRO | MOROCCO | THE NETHERLANDS | NEW ZEALAND | NORWAY | POLAND | PORTUGAL | PHILIPPINES | QATAR | ROMANIA | RUSSIA | SAUDI ARABIA | SERBIA | SINGAPORE | SLOVAKIA | SLOVENIA | SOUTH AFRICA | SOUTH KOREA | SPAIN | SUDAN | SWEDEN | SWITZERLAND | SYRIA | TAIWAN | THAILAND | TURKEY | UKRAINE | UNITED ARAB EMIRATES | UNITED KINGDOM | USA | UZBEKISTAN | VIETNAM

## Tapflo Group Companies

### Austria

Tapflo Austria  
Tel: +43 732 27292910  
sales@tapflo.at

### Azerbaijan

Tapflo Azerbaijan LLC  
Tel: +994 502660799  
sales@tapflo.az

### Baltic States

Tapflo Latvia  
Tel: +371 67472205  
sales@tapflo.lv

### Belarus

Tapflo Belarus  
Tel: +375 17 3934609  
sales@tapflo.by

### Bulgaria

Tapflo EOOD  
Tel: +359 (2) 974 18 54  
office@tapflo.org

### Canada

Tapflo Canada  
Tel: +1 514 813 5754  
canada@tapflo.com

### Croatia

Tapflo GmbH  
Tel: +385 91 4884 666  
sales@tapflo.hr

### Czech Republic

Tapflo s.r.o.  
Tel: +420 513033924  
tapflo@tapflo.cz

### China

Tapflo (Wuxi)  
Tel: +86 510 8241 7602  
sales@tapflo.cn

### Denmark

Tapflo Danmark  
Tel: +45 36 454600  
info@tapflo.dk

### France

Tapflo France  
Tel: +33 1 34 78 82 40  
info@tapflo.fr

### Georgia

Tapflo Georgia  
Tel: +995 577 463010  
sales@tapflo.ge

### India

Tapflo Fluid Handling India  
Pvt Ltd  
Tel: +91 20 65000215  
ad@tapflo.in

### Ireland

Tapflo Ireland Ltd  
Tel: +353 1 2011911  
info@tapflo.ie

### Italy

Tapflo Italia  
Tel: +39 0362307698  
info@tapfloitalia.com

### Japan

Tapflo Japan K.K.  
Tel: +81-3-6240-3510  
tapflojp@tapflo.co.jp

### Kazakhstan

Tapflo Kazakstan  
Tel: +7 727 3278347  
sales@tapflo.kz

### Poland

Tapflo Sp. z o.o.  
Tel: +48 58 530 42 00  
info@tapflo.pl

### Romania

S.C. Tapflo Rom. S.r.l.  
Tel: +40 21 3451255  
sales@tapflo.ro

### Russia

Tapflo Company  
Tel: +7 495 232 18 28  
sales@tapflo.com.ru

### Serbia

Tapflo d.o.o.  
Tel: +381 21 44 58 08  
sales@tapflo.rs

### Slovakia

Tapflo s.r.o.  
Tel: +421 911 137 883  
tapflo@tapflo.sk

### Slovenia

Tapflo GmbH  
Tel: +386 68 613 474  
sales@tapflo.hr

### Spain

Tapflo Iberica  
Tel: +34 91 8093182  
avives@tapfloiberica.es

### South Africa

Tapflo (Pty) Ltd  
Tel: +27 31 701 5255  
sales@tapflo.co.za

### Turkey

Tapflo Makina Ltd  
Tel: +90 216 467 33 11  
sales@tapflo.com.tr

### Ukraine

TOB Tapflo  
Tel: +380 44 222 68 44  
sales@tapflo.com.ua

### Uzbekistan

Tapflo Uzbekistan  
Tel: +998 712340940  
sales@tapflo.uz

### United Kingdom

Tapflo (UK) Ltd  
Tel: +44 2380 252325  
sales@tapflo pumps.co.uk