

tapflo®

HYGIENIC PUMPS

Clean and safe in real life

edition 2015 rev 1

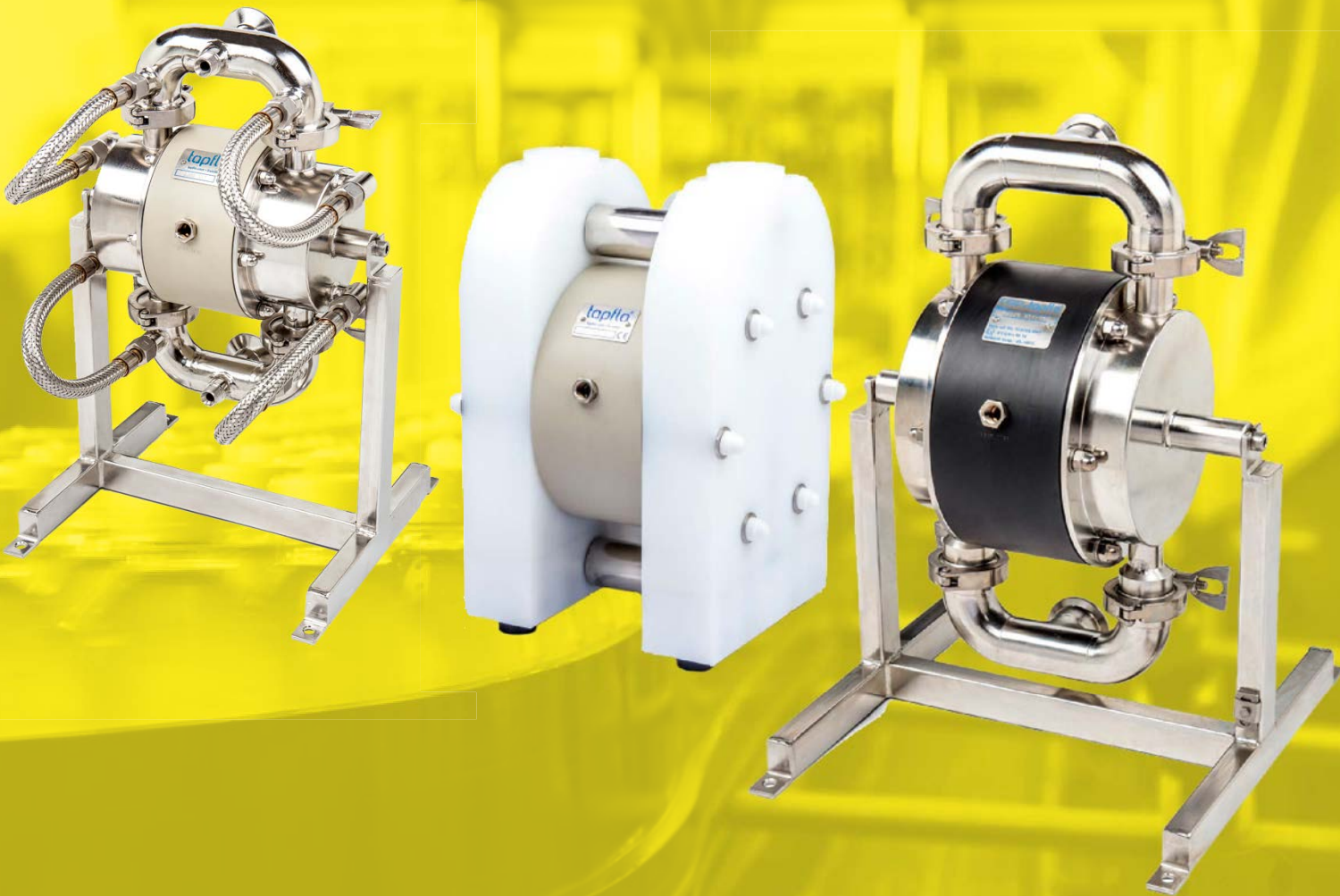

» All about your flow

www.tapflo.com



topflo[®]

food & beverages industry



when it comes to being clean

hygienic pumping

Whether you are handling food, beverages, cosmetics, pharmaceuticals or biotech products the fundamentals are very basic – the process equipment shall not contaminate the handled product and it shall be cleanable in desired way. So how will you be able to determine if your equipment such as pumps is safe and fulfill your requirements? A number of standards and directives for hygienic equipment are applicable. In this brochure you will learn more about them and how we have incorporated them in our hygienic product range.

The chart on the next pages give you a brief introduction to applicable directives, norms and regulations and how they are incorporated in our pump range.

pharmaceutical &
biotechnology industry



cosmetic industry



Providing accurate pumps to fulfill your needs

✓ = standard ✓ = option

AODD Diaphragm pumps



	Pharmaceutical	EHEDG pumps	Sanitary pumps
USP VI approved materials	✓	✓	✓
EHEDG certified products		✓	
FDA §21 CFR 177 materials	✓	✓	✓
EN 10204 material traceability	✓	✓	✓
EC 1935/2004 regulation	✓	✓	✓
CE conformance	✓	✓	✓
ATEX Directive 94/9/EC	✓	✓	✓



USP VI approved materials

U.S. Pharmacopeial Convention (USP) class I to VI defines how a plastic or rubber material may be exposed to human tissue. Class VI requires the most stringent testing and such materials may be used for example in implant devices.



EHEDG certified products

The EHEDG (European Hygienic Engineering & Design Group) certificate proves that the design is according to the hygienic guidelines. Furthermore certified products are cleanability tested.



FDA §21 CFR 177 materials

FDA (U.S. Food and Drug Administration) §21 CFR 177 lists polymers, e.g. rubber and plastic materials approved for equipment in contact with food products.

EN 10204

EN 10204 material traceability

The EN 10204 norm gives you a checklist and traceability of materials used in the equipment. 2.1 is a general statement of compliance with material specifications, while 3.1 provides specific track records all the way to the steel mill batch (normally only on metals in contact with the product).



EC 1935/2004 regulation

This EU regulation applies to all food contact materials, e.g. metals, plastics and rubber materials. It requires that these materials are safe, are labeled with the glass-and-fork symbol, are traceable throughout the production chain (according to above EN 10204) and that they are produced according to good manufacturing practice (GMP).



CE conformance

A product classified as machinery that carries the CE mark fulfill the essential health and safety requirements of the EC Machinery Directive 2006/42/EEC.



ATEX Directive 94/9/EC

Equipment intended and approved for safe operation in potentially explosive atmospheres. The equipment is divided in main groups, categories, apparatus groups and temperature classes to define its suitability in the actual zone.

	Pulsation dampeners		Centrifugal pumps		Hose pumps	
--	----------------------------	--	--------------------------	--	-------------------	--



		✓	✓			
--	--	---	---	--	--	--

		✓				
--	--	---	--	--	--	--

✓	✓	✓	✓		✓	✓
---	---	---	---	--	---	---

✓	✓	✓	✓		✓	✓
---	---	---	---	--	---	---

		✓	✓		✓	✓
--	--	---	---	--	---	---

✓	✓	✓	✓	✓	✓	✓
---	---	---	---	---	---	---

✓	✓	✓	✓		✓	
---	---	---	---	--	---	--

Integrated in your plant

Clean water

Clean water or so called deionized water is used (clean water free from carbon molecules) is used widely in food- a pharmaceutical processing plants. Here it is extremely important using 316L (low carbon), use of normal 316 will cause "picking" inside the pump when carbon molecules are "stolen back" by the deionized water. This will turn deionized water to normal water, the process will fail and also the pump will be destroyed. The solution is using the Tapflo CTH centrifugal pump that always come with 316L wetted materials and optionally sintered (pure) silicon carbide seals.



CIP feeding pump

CIP cleaning

CIP cleaning (Clean In Place) is an automatic cleaning system where the pipe system with its pumps, valves and other equipment is flushed with a cleaning liquid, all while the system is assembled. To obtain sufficient cleanliness, the CIP flow speed in the system is minimum 1.5 to 2.0 m/s, relatively low back pressure up to 1 bar is required. Tapflo CTH range is commonly used as CIP pump for pipe systems from 3/4" up to 4" (DN 15 up to DN 100). For the concentrated cleaning chemicals, small sized 3/8" or 1/2" plastic diaphragm pumps are typically used.



CIP preparation pump



CIP return pump

Process pump for handling hygienic liquids



SIP cleaning

SIP cleaning, Sterilize In Place is widely used in pharmaceutical industry, but becomes more and more popular also in food and beverage industries. Two methods are used for SIP, either the classic steam injection where basically no pumps are required, or liquid sterilization in closed pressurized (2 bar) system. This second method saves process equipment like pumps from dry running, saving costs and life of mechanical seals etc.

Integrated in your plant

Clean water

Clean water or so called deionized water is used (clean water free from carbon molecules) is used widely in food- a pharmaceutical processing plants. Here it is extremely important using 316L (low carbon), use of normal 316 will cause "picking" inside the pump when carbon molecules are "stolen back" by the deionized water. This will turn deionized water to normal water, the process will fail and also the pump will be destroyed. The solution is using the Tapflo CTH centrifugal pump that always come with 316L wetted materials and optionally sintered (pure) silicon carbide seals.



CIP feeding pump

CIP cleaning

CIP cleaning (Clean In Place) is an automatic cleaning system where the pipe system with its pumps, valves and other equipment is flushed with a cleaning liquid, all while the system is assembled. To obtain sufficient cleanliness, the CIP flow speed in the system is minimum 1.5 to 2.0 m/s, relatively low back pressure up to 1 bar is required. Tapflo CTH range is commonly used as CIP pump for pipe systems from 3/4" up to 4" (DN 15 up to DN 100). For the concentrated cleaning chemicals, small sized 3/8" or 1/2" plastic diaphragm pumps are typically used.



CIP preparation pump



CIP return pump

Process pump for handling hygienic liquids



SIP cleaning

SIP cleaning, Sterilize In Place is widely used in pharmaceutical industry, but becomes more and more popular also in food and beverage industries. Two methods are used for SIP, either the classic steam injection where basically no pumps are required, or liquid sterilization in closed pressurized (2 bar) system. This second method saves process equipment like pumps from dry running, saving costs and life of mechanical seals etc.

Integrated in your plant

Clean water

Clean water or so called deionized water is used (clean water free from carbon molecules) is used widely in food- a pharmaceutical processing plants. Here it is extremely important using 316L (low carbon), use of normal 316 will cause "picking" inside the pump when carbon molecules are "stolen back" by the deionized water. This will turn deionized water to normal water, the process will fail and also the pump will be destroyed. The solution is using the Tapflo CTH centrifugal pump that always come with 316L wetted materials and optionally sintered (pure) silicon carbide seals.



CIP feeding pump

CIP cleaning

CIP cleaning (Clean In Place) is an automatic cleaning system where the pipe system with its pumps, valves and other equipment is flushed with a cleaning liquid, all while the system is assembled. To obtain sufficient cleanliness, the CIP flow speed in the system is minimum 1.5 to 2.0 m/s, relatively low back pressure up to 1 bar is required. Tapflo CTH range is commonly used as CIP pump for pipe systems from 3/4" up to 4" (DN 15 up to DN 100). For the concentrated cleaning chemicals, small sized 3/8" or 1/2" plastic diaphragm pumps are typically used.



CIP preparation pump



CIP return pump

Process pump for handling hygienic liquids



SIP cleaning

SIP cleaning, Sterilize In Place is widely used in pharmaceutical industry, but becomes more and more popular also in food and beverage industries. Two methods are used for SIP, either the classic steam injection where basically no pumps are required, or liquid sterilization in closed pressurized (2 bar) system. This second method saves process equipment like pumps from dry running, saving costs and life of mechanical seals etc.

handling liquids in hygienic industries

refining your process

In your production plant there are numerous of pump applications. Main focus is probably pumps for the ready products and clean water, however there are probably just as much needs of pumps for ingredients, additives and auxiliary applications like detergents, chemicals and solvents. Whichever part of your process, we will provide the suitable pump solution.

Moving the product

The above mentioned applications are keystones in almost all food-beverage- and pharmaceutical processes. However pumping the ready product is usually the greatest challenge. The first challenge is that the nature of the product might be demanding for process equipment like pumps; high viscosity, big solids or abrasive ingredients. The second challenge is that the product shall maintain its shape and nature after the process, without any destroying of solids, shearing or contamination. For these types of duties, a cleanable pump design, selection of materials and traceability are crucial. CTH centrifugal pumps, sanitary and EHEDG diaphragms pumps and PT/PTL hose pumps are used.

ump

Application examples - food & beverage

World famous food & beverage producers as well as smaller local makers use Tapflo pumps in their processes. These two pages show a selection of them.

Kraft

Nestle

Coca Cola

Carlsberg

Unilever

Danone



Food Industry

■ Pumped media

Sugar and starch syrups – chocolate products

■ Pump

TJ125 STT sanitary pump with heating jacket

■ Application description

Transfer at ambient temperature



Food Industry

■ Pumped media

Curd chesse - dairy products

■ Pump

T425 SWT sanitary diaphragm pump

■ Application description

Filling of packing machine, 9 mm grain contents, ambient temperature



Food Industry

■ Pumped media

Vanilla custard - dairy products

■ Pump

T244 STT aseptic EHEDG diaphragm pump

■ Application description

Transfer to filling machine, ambient temperature



Food Industry

■ Pumped media

Chocolate glaze for ice cream – dairy products

■ Pump

CTH BB hygienic centrifugal pump

■ Application description

Emptying of ice cream machine

Application examples - pharmaceutical, biotech & cosmetics

Some of the most exclusive Tapflo pumps are used in multinational pharmaceutical-, biotech- and cosmetic industries. A handful of examples you find on these pages.

Glaxo Smith Kline

Pfizer

Novartis

Astra Zeneca

Eli Lilly



Pharmaceutical Industry

- **Pumped media**
Oils and ethanol
- **Pump**
T80 STT sanitary diaphragm pump
- **Application description**
Pumping from tanks, transport and dosing



Pharmaceutical Industry

- **Pumped media**
Mushroom culture organic suspension
- **Pump**
CTH CE hygienic centrifugal pump and TX30 STT sanitary diaphragm pump
- **Application description**
Unloading from fermentation process reactor (CTH pump) and emptying of mushroom culture sediments (TX30 pump)



Pharmaceutical Industry

- **Pumped media**
Solvent pumping
- **Pump**
TX120 STT industrial stainless steel diaphragm pump
- **Application description**
Mobile nit for solvent pumping, with nitrogen pipe purge system



Hygiene Products

- **Pumped media**
Shampoos and liquid soaps
- **Pump**
T125 STS sanitary diaphragm pump
- **Application description**
Transfer of shampoos and liquid soaps directly to filling machines

Product range

Fast Facts:

- Capacity 0-820 l/min (216 US gpm)
- Pressure 0 – 8 bar (116 psi)
- Sizes Sanitary 1" up to 2 1/2"
EHEDG 1 1/2" up to 2 1/2"
Plastic 1/8" up to 3"
- Materials PE, PTFE,
and stainless steel AISI 316L
(other material on request)

Major Benefits:

- Very easy to control capacity and pressure by regulating air pressure and flow
- Self-priming and able to run dry without damage
- Hygienic smooth surface and long life diaphragms
- Pollution free and non-stalling air valve



EHEDG pumps



Sanitary pumps

EHEDG aseptic diaphragm pumps

The EHEDG aseptic series AODD pumps are designed to pump food products, cosmetics or pharmaceuticals. This EHEDG (European Hygienic Engineering & Design Group) series is certified by the Danish Technological Institute and it guarantees that the design and selected materials are according to the guidelines. Apart from the design approval, the series has also been clean ability tested and approved.

The pumps are made from AISI 316L stainless steel with mirror polished surface finish Ra 0.8 (standard) or Ra 0.4 upon request. Plastics and rubbers are FDA approved and upon request USP VI approved. The pumps are designed for cleaning and sterilization in place (C.I.P. and S.I.P.).

Furthermore the manifold clamp connections and housing screws make it quick and easy to dismantle and manually clean the pumps internally. 3.1 trace ability documents will always follow when you receive your Tapflo EHEDG aseptic pump.

Sanitary pumps diaphragm pumps

This pump series is sanitary designed with wetted metal parts in electro polished stainless steel AISI 316L, with possibility of extra fine surface finish Ra 0.8. Plastics and rubbers are FDA approved. The pumps are designed for cleaning and sterilization in place (C.I.P. and S.I.P.). Furthermore the manifold clamp connections and housing screws make it quick and easy to dismantle and manually clean the pumps internally.

meeting your needs with versatile

air operated diaphragm pumps

Tapflo AODD range is extremely versatile, handling all sorts of liquid products; thin, thick, with solids, and sensitive.

Plastic diaphragm pumps

Pumps made of polyethylene (PE HD) or virgin PTFE plastics handle all kind of chemicals, in food and beverage industries they are mainly used for pumping C.I.P. chemicals. In pharmaceutical industries they handle all type of raw chemicals. The pumps are available also in explosion proof ATEX-marked versions.

PE & PTFE pumps



Metal diaphragm pumps

Molded industrial pumps in glass blast stainless steel AISI 316L, typically used for raw chemicals, solvents and waste applications. The pumps are available also in explosion proof ATEX-marked versions.

Available options:

- Heating jacket is available on the sanitary pumps, typically used in chocolate and glaze applications
- Flap valves is an option on sanitary pumps, the perfect solution for gentle pumping of big size solids up to 48 mm.
- Pneumatic systems are available for all our diaphragm pumps, adding increased safety by automatic control and monitoring:
 - Diaphragm rupture guardian system
 - Level control
 - Dead head and dry run guardian system
 - Start & start units
 - Batch control



Metal pumps

Sanitary active pulsation dampeners:

The sanitary series of Tapflo dampeners has been designed in particular for food, beverage, pharmaceutical and cosmetic industries where cleanliness and sterile environment is necessary.

Made to be clean

The dampener is designed and prepared for cleaning and sterilization in place – C.I.P. and S.I.P. These are automatic cleaning and disinfection procedures implemented in these industries so it is essential that our product are prepared to comply with these procedures.



Product range

Fast Facts Centrifugal Pumps:

- Capacity 0-60 m³/h (264 US gpm)
- Head 2 – 47 m (154 ft)
- Sizes ¾" up to 2 ½", 0.12– 11 kW
- Materials PP, PVDF and stainless steel
AISI 316L

Major Benefits Centrifugal Pumps:

- The centrifugal principle gives a very high capacity
- Pumps made from AISI 316L, ideal for any food contact applications
- Big choice of sealing face materials
- Many options available, see below

Our centrifugal pumps are very efficient, pumping low and medium viscous liquids with high capacity in relation to the size of the pumps. Mechanical sealed pumps in stainless steel, as well as seal less pumps in plastics PP and PVDF are available.



CTH pumps

CTH centrifugal pumps

This hygienic single mechanical sealed pump series is supplied with electro polished Ra 0.8 pump casing and internals. This pump series is especially dedicated for hygienic duties in food and beverage industries. A wide range of sealing face materials are available – ceramic, graphite, SiC and with o-rings in FDA approved EPDM, FKM or FEP.

A number of special executions are available:

- Heating jacket – Great protection for the mechanical seal in applications with risk of solidification, example chocolate glaze, paraffin, starch, glucose syrup and margarine etc.
- Hygienic shroud – Easier to keep the pump externals clean, protects the motor from spraying water.
- Casing drainage – By positioning the outlet horizontal at the bottom, or by means of a drain connection the pump features a hygienic and automatic draining.
- Long coupled – The perfect solution for hot products like eatable oils



CTM pumps

CTM magnetic drive centrifugal pumps

These nonmetallic magnetic drive centrifugal pumps are ideal for low viscous chemicals. Made from either PP or PVDF, they safely handle concentrated C.I.P. chemicals.

meeting your needs with versatile

centrifugal and hose pumps

Our peristaltic pumps, PT & PTL, combine the best available materials with smart design solutions in order to maximize running time and minimize maintenance.

PT and PTL peristaltic pumps - hose pumps

The high pressure PT series allow pressures up to 15 bar, while PTL is the low pressure series with max pressure 4 bar.



PT pumps



PTL pumps

Fast Facts Peristaltic Pumps:

- Capacity PT: up to 88 m³/h (387 US gpm)
PTL: up to 10 m³/h (44 US gpm)
- Pressure PT: up to 15 bar (218 psi)
PTL: up to 4 bar (58 psi)
- Sizes PT: 5 up to 125 mm hose
PTL: 9 up to 45 mm hose
- Hose materials PT: NR, NR food (FDA), NBR, NBR food (FDA), EPDM, Hypalon, FKM
PTL: Neoprene, Norprene, Silicone, Pharmed, Hypalon, EPDM, NR, NBR

Major Benefits Peristaltic Pumps:

- Easy maintenance, hose is only worn component
- Long hose life with unique hose composition
- Great choice of food approved hose materials
- Reversible flow
- Self-priming up to 9.8 m
- Able to pump high viscous products

Tailormade pump systems

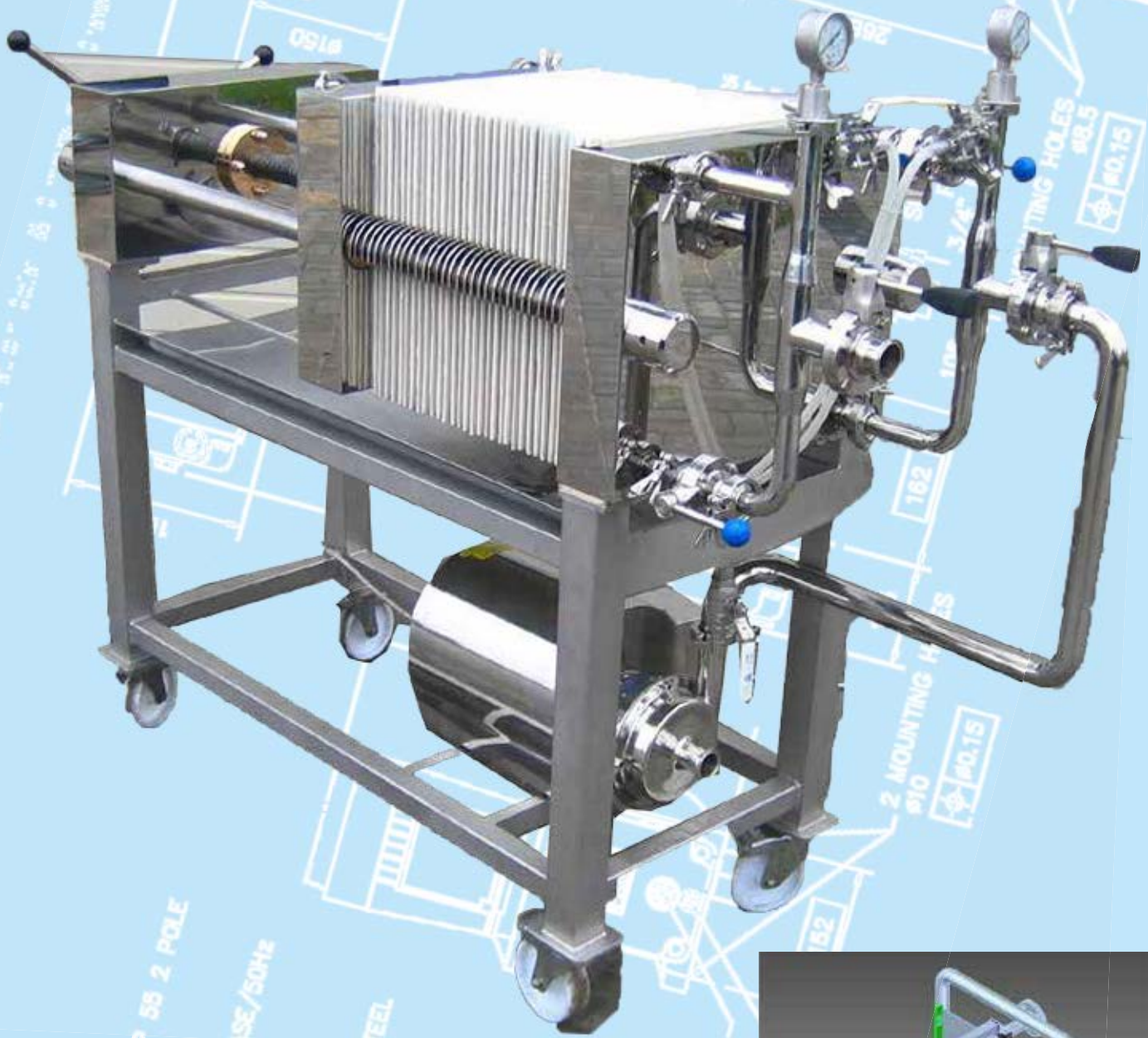

Mobile filter press unit for fruit squeezing, CTH pumps used for pumping fruit juice to storage tanks.

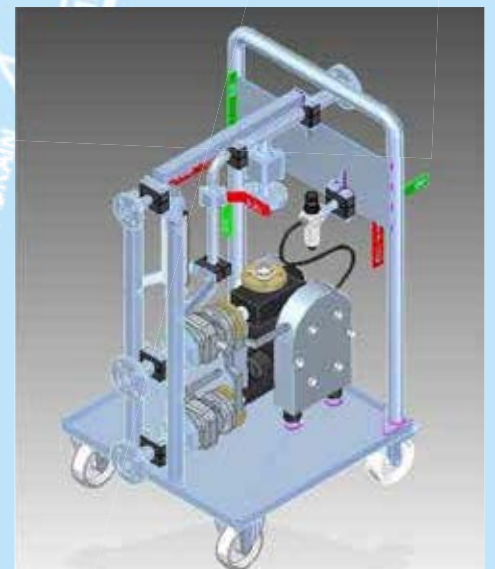

We build the whatever you need through our

engineering to order system

Engineering to Order is an engineering and manufacturing procedure which goal is to deliver specific solution desired by addressed process. In other words engineers are faced with special and most often unique problem and thereafter they try to provide adequate solution to solve or even improve proposed or existing process.

Engineering to Order is an answer to very many process optimization deliberations. Why is that? Even though we have so many products on the market there is still incomparable and unlimited number of situations where we just can't use them in the required manner. This is exactly the moment when Engineering to Order comes into play.

Where is a need people are thinking!

It is most common to apply those kinds of machinery to production/close transport facilities. However there is quite a few other possible ways of Eng. to Order application. There have been cases where one specially provided solution became standard equipment and have a potential to come into series production.

Typically Engineering to Order projects are alive and still changing until delivery time or sometimes even after. This is because we are committed to provide customer with best care possible but also we want to learn how our solutions are performing and what else can we do to improve.



GROSVENOR	
DUTY	SUBC00-0
	0 BAK
	0 BAR
	100 L/M
	030 L/000
MOTOR (STD)	
TYPE	380 FRAME IP
SPEED	1500 RPM
POWER	0.38 KW
SUPPLY	0.38 KW
OPERATION	415 VAC/3 PH
	CONTINUOUS
MATERIAL	MATERIAL
FOOTHEAD	IP54
	STL STABILIZED
DIAPHRAGM	415V
TEMPERATURE	40°C MIN
	50°C MAX - 415V
	70°C MAX - 230V
HEIGHT	350
MOTOR CAN BE ROTATED 90°	
INCREMENTS TO PROVIDE ALTERNATIVE	
TORSIONAL POS POSITIONS	

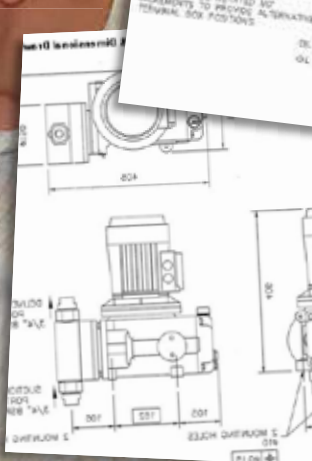

topflo®

our ambition is to

make



Tapflo evolvement in the world

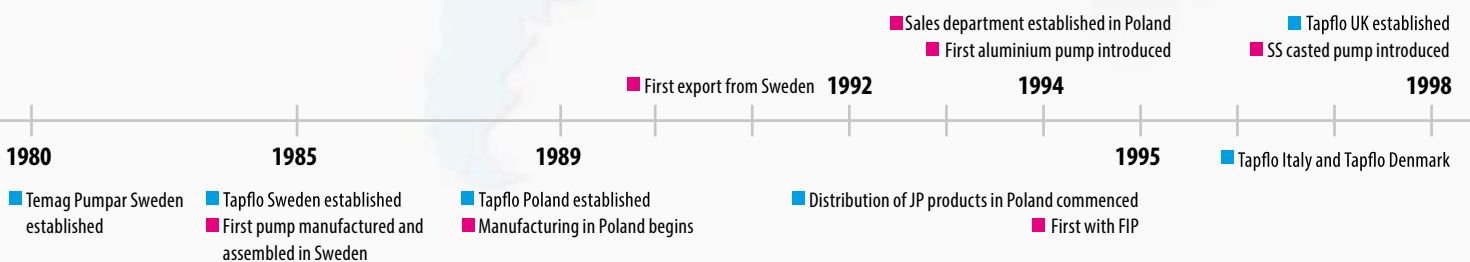

pumping easy

what ever
where ever
when ever

Tapflo is a leading pump manufacturer with the ambition to provide a wide range of premium products for various industrial applications. We are represented by Tapflo companies and distributors in more than 50 countries, with the main production located in Europe and Asia. The head quarters is situated in Sweden.

■ Long term engagement is our core

Our aim - to continue to provide first rate products according to your needs and the latest technology is mutually beneficial. That is why we see each customer relationship as a long term commitment.

■ Local means on your terms

You can summarize Tapflo's marketing philosophy with the words: We think global but act locally.

■ Flexibility - our idea of a good service

We are prepared to deal with reality, knowing that in practice this means answering questions, offering solutions and supply spare parts with a minimal loss of time.

■ Customizing the product to the needs

Our intention is always to help our clients find the most cost effective solutions to increase their company's efficiency. If this means changing the design of the pump we see it as a challenge - not a problem.

■ To produce is to develop

When you are actively involved in the manufacture of a product, it is almost impossible not to discover ways to improve it. This allows us to frequently offer pumps that are even more sustainable and efficient.

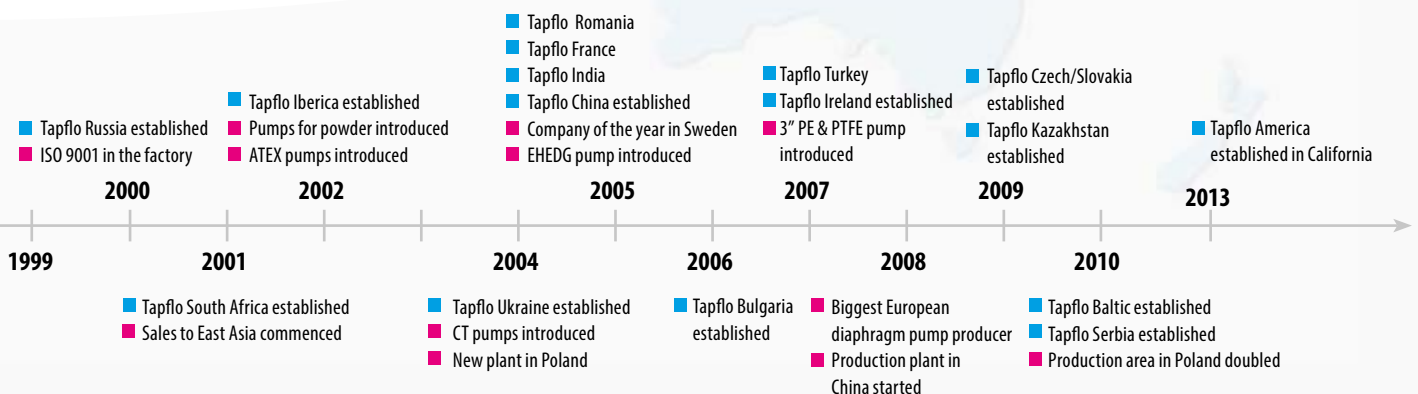

TAPFLO AB

Sweden

Filaregatan 4 | S-442 34 Kungälv

Tel: +46 303 63390

Fax: +46 303 19916

E-mail addresses:

Commercial questions: sales@tapflo.com

Orders: order@tapflo.com

Tech support: support@tapflo.com

Tapflo products and services are available in 64 countries on 6 continents.

Tapflo is represented worldwide by own Tapflo Group Companies and carefully selected distributors assuring highest Tapflo service quality for our customers' convenience.

AUSTRALIA | AUSTRIA | AZERBAIJAN | BELARUS | BELGIUM | BOSNIA | BRAZIL | BULGARIA | CHILE | CHINA | COLOMBIA | CROATIA | CZECH REPUBLIC | DENMARK | ECUADOR | ESTONIA | FINLAND | FRANCE | GREECE | GEORGIA | GERMANY | HONG-KONG | HUNGARY | INDIA | INDONESIA | IRAN | IRELAND | ISRAEL | ITALY | JAPAN | KAZAKHSTAN | LATVIA | LITHUANIA | MACEDONIA | MALAYSIA | MEXICO | MONTENEGRO | THE NETHERLANDS | NEW ZEALAND | NORWAY | POLAND | PORTUGAL | PHILIPPINES | ROMANIA | RUSSIA | SERBIA | SINGAPORE | SLOVAKIA | SLOVENIA | SOUTH AFRICA | SOUTH KOREA | SPAIN | SWEDEN | SWITZERLAND | SYRIA | TAIWAN | THAILAND | TURKEY | UKRAINE | UNITED ARAB EMIRATES | UNITED KINGDOM | USA | UZBEKISTAN | VIETNAM

Tapflo Group Companies

Austria

Tapflo Austria
Tel: +43 732 27292910
sales@tapflo.at

China

Tapflo (Wuxi)
Tel: +86 510 8241 7602
sales@tapflo.cn

Japan

Tapflo Japan K.K.
Tel: +81-3-6240-3510
tapflojp@tapflo.co.jp

Slovenia

Tapflo GmbH
Tel: +386 68 613 474
sales@tapflo.hr

Azerbaijan

Tapflo Azerbaijan LLC
Tel: +994 502660799
sales@tapflo.az

Denmark

Tapflo Danmark
Tel: +45 36 454600
info@tapflo.dk

Kazakhstan

Tapflo Kazakstan
Tel: +7 727 3278347
sales@tapflo.kz

Spain

Tapflo Iberica
Tel: +34 91 8093182
avives@tapfloiberica.es

Baltic States

Tapflo Latvia
Tel: +371 67472205
sales@tapflo.lv

France

Tapflo France
Tel: +33 1 34 78 82 40
info@tapflo.fr

Poland

Tapflo Sp. z o.o.
Tel: +48 58 530 42 12
info@tapflo.pl

South Africa

Tapflo (Pty) Ltd
Tel: +27 31 701 5255
sales@tapflo.co.za

Belarus

Tapflo Belarus
Tel: +375 17 3934609
sales@tapflo.by

Georgia

Tapflo Georgia
Tel: +995 577 463010
sales@tapflo.ge

Romania

S.C. Tapflo Rom. S.r.l.
Tel: +40 21 3451255
sales@tapflo.ro

Turkey

Tapflo Makina Ltd
Tel: +90 216 467 33 11
sales@tapflo.com.tr

Bulgaria

Tapflo EOOD
Tel: +359 (0)2 974 18 54
office@tapflo.bg

India

Tapflo Fluid Handling India Pvt Ltd
Tel: +91 20 65000215
ad@tapflo.in

Russia

Tapflo Company
Tel: +7 495 232 18 28
sales@tapflo.com.ru

Ukraine

TOB Tapflo
Tel: +380 44 222 68 44
sales@tapflo.com.ua

Croatia

Tapflo GmbH
Tel: +385 91 4884 666
sales@tapflo.hr

Ireland

Tapflo Ireland Ltd
Tel: +353 1 2011911
info@tapflo.ie

Serbia

Tapflo d.o.o.
Tel: +381 21 44 58 08
sales@tapflo.rs

Uzbekistan

Tapflo Uzbekistan
Tel: +998 712370940
sales@tapflo.uz

Czech Republic

Tapflo s.r.o.
Tel: +420 513 033 924
tapflo@tapflo.cz

Italy

Tapflo Italia
Tel: +39 0362307698
info@tapfloitalia.com

Slovakia

Tapflo s.r.o.
+421 911 137 883
tapflo@tapflo.sk

United Kingdom

Tapflo (UK) Ltd
Tel: +44 2380 252325
sales@tapflopumps.co.uk

handling liquids in hygienic industries

refining your process

In your production plant there are numerous of pump applications. Main focus is probably pumps for the ready products and clean water, however there are probably just as much needs of pumps for ingredients, additives and auxiliary applications like detergents, chemicals and solvents. Whichever part of your process, we will provide the suitable pump solution.

Moving the product

The above mentioned applications are keystones in almost all food-beverage- and pharmaceutical processes. However pumping the ready product is usually the greatest challenge. The first challenge is that the nature of the product might be demanding for process equipment like pumps; high viscosity, big solids or abrasive ingredients. The second challenge is that the product shall maintain its shape and nature after the process, without any destroying of solids, shearing or contamination. For these types of duties, a cleanable pump design, selection of materials and traceability are crucial. CTH centrifugal pumps, sanitary and EHEDG diaphragms pumps and PT/PTL hose pumps are used.

ump

Application examples - food & beverage

World famous food & beverage producers as well as smaller local makers use Tapflo pumps in their processes. These two pages show a selection of them.

Kraft

Nestle

Coca Cola

Carlsberg

Unilever

Danone



Food Industry

■ Pumped media

Sugar and starch syrups – chocolate products

■ Pump

TJ125 STT sanitary pump with heating jacket

■ Application description

Transfer at ambient temperature



Food Industry

■ Pumped media

Curd chesse - dairy products

■ Pump

T425 SWT sanitary diaphragm pump

■ Application description

Filling of packing machine, 9 mm grain contents, ambient temperature



Food Industry

■ Pumped media

Vanilla custard - dairy products

■ Pump

T244 STT aseptic EHEDG diaphragm pump

■ Application description

Transfer to filling machine, ambient temperature



Food Industry

■ Pumped media

Chocolate glaze for ice cream – dairy products

■ Pump

CTH BB hygienic centrifugal pump

■ Application description

Emptying of ice cream machine

Application examples - pharmaceutical, biotech & cosmetics

Some of the most exclusive Tapflo pumps are used in multinational pharmaceutical-, biotech- and cosmetic industries. A handful of examples you find on these pages.

Glaxo Smith Kline

Pfizer

Novartis

Astra Zeneca

Eli Lilly



Pharmaceutical Industry

- **Pumped media**
Oils and ethanol
- **Pump**
T80 STT sanitary diaphragm pump
- **Application description**
Pumping from tanks, transport and dosing



Pharmaceutical Industry

- **Pumped media**
Mushroom culture organic suspension
- **Pump**
CTH CE hygienic centrifugal pump and TX30 STT sanitary diaphragm pump
- **Application description**
Unloading from fermentation process reactor (CTH pump) and emptying of mushroom culture sediments (TX30 pump)



Pharmaceutical Industry

- **Pumped media**
Solvent pumping
- **Pump**
TX120 STT industrial stainless steel diaphragm pump
- **Application description**
Mobile nit for solvent pumping, with nitrogen pipe purge system



Hygiene Products

- **Pumped media**
Shampoos and liquid soaps
- **Pump**
T125 STS sanitary diaphragm pump
- **Application description**
Transfer of shampoos and liquid soaps directly to filling machines

Product range

Fast Facts:

- Capacity 0-820 l/min (216 US gpm)
- Pressure 0 – 8 bar (116 psi)
- Sizes Sanitary 1" up to 2 1/2"
EHEDG 1 1/2" up to 2 1/2"
Plastic 1/8" up to 3"
- Materials PE, PTFE,
and stainless steel AISI 316L
(other material on request)

Major Benefits:

- Very easy to control capacity and pressure by regulating air pressure and flow
- Self-priming and able to run dry without damage
- Hygienic smooth surface and long life diaphragms
- Pollution free and non-stalling air valve



EHEDG pumps



Sanitary pumps

EHEDG aseptic diaphragm pumps

The EHEDG aseptic series AODD pumps are designed to pump food products, cosmetics or pharmaceuticals. This EHEDG (European Hygienic Engineering & Design Group) series is certified by the Danish Technological Institute and it guarantees that the design and selected materials are according to the guidelines. Apart from the design approval, the series has also been clean ability tested and approved.

The pumps are made from AISI 316L stainless steel with mirror polished surface finish Ra 0.8 (standard) or Ra 0.4 upon request. Plastics and rubbers are FDA approved and upon request USP VI approved. The pumps are designed for cleaning and sterilization in place (C.I.P. and S.I.P.).

Furthermore the manifold clamp connections and housing screws make it quick and easy to dismantle and manually clean the pumps internally. 3.1 trace ability documents will always follow when you receive your Tapflo EHEDG aseptic pump.

Sanitary pumps diaphragm pumps

This pump series is sanitary designed with wetted metal parts in electro polished stainless steel AISI 316L, with possibility of extra fine surface finish Ra 0.8. Plastics and rubbers are FDA approved. The pumps are designed for cleaning and sterilization in place (C.I.P. and S.I.P.). Furthermore the manifold clamp connections and housing screws make it quick and easy to dismantle and manually clean the pumps internally.

meeting your needs with versatile

air operated diaphragm pumps

Tapflo AODD range is extremely versatile, handling all sorts of liquid products; thin, thick, with solids, and sensitive.

Plastic diaphragm pumps

Pumps made of polyethylene (PE HD) or virgin PTFE plastics handle all kind of chemicals, in food and beverage industries they are mainly used for pumping C.I.P. chemicals. In pharmaceutical industries they handle all type of raw chemicals. The pumps are available also in explosion proof ATEX-marked versions.

PE & PTFE pumps



Metal diaphragm pumps

Molded industrial pumps in glass blast stainless steel AISI 316L, typically used for raw chemicals, solvents and waste applications. The pumps are available also in explosion proof ATEX-marked versions.

Available options:

- Heating jacket is available on the sanitary pumps, typically used in chocolate and glaze applications
- Flap valves is an option on sanitary pumps, the perfect solution for gentle pumping of big size solids up to 48 mm.
- Pneumatic systems are available for all our diaphragm pumps, adding increased safety by automatic control and monitoring:
 - Diaphragm rupture guardian system
 - Level control
 - Dead head and dry run guardian system
 - Start & start units
 - Batch control



Metal pumps

Sanitary active pulsation dampeners:

The sanitary series of Tapflo dampeners has been designed in particular for food, beverage, pharmaceutical and cosmetic industries where cleanliness and sterile environment is necessary.

Made to be clean

The dampener is designed and prepared for cleaning and sterilization in place – C.I.P. and S.I.P. These are automatic cleaning and disinfection procedures implemented in these industries so it is essential that our product are prepared to comply with these procedures.



Product range

Fast Facts Centrifugal Pumps:

- Capacity 0-60 m³/h (264 US gpm)
- Head 2 – 47 m (154 ft)
- Sizes ¾" up to 2 ½", 0.12– 11 kW
- Materials PP, PVDF and stainless steel
AISI 316L

Major Benefits Centrifugal Pumps:

- The centrifugal principle gives a very high capacity
- Pumps made from AISI 316L, ideal for any food contact applications
- Big choice of sealing face materials
- Many options available, see below

Our centrifugal pumps are very efficient, pumping low and medium viscous liquids with high capacity in relation to the size of the pumps. Mechanical sealed pumps in stainless steel, as well as seal less pumps in plastics PP and PVDF are available.



CTH pumps

CTH centrifugal pumps

This hygienic single mechanical sealed pump series is supplied with electro polished Ra 0.8 pump casing and internals. This pump series is especially dedicated for hygienic duties in food and beverage industries. A wide range of sealing face materials are available – ceramic, graphite, SiC and with o-rings in FDA approved EPDM, FKM or FEP.

A number of special executions are available:

- Heating jacket – Great protection for the mechanical seal in applications with risk of solidification, example chocolate glaze, paraffin, starch, glucose syrup and margarine etc.
- Hygienic shroud – Easier to keep the pump externals clean, protects the motor from spraying water.
- Casing drainage – By positioning the outlet horizontal at the bottom, or by means of a drain connection the pump features a hygienic and automatic draining.
- Long coupled – The perfect solution for hot products like eatable oils



CTM pumps

CTM magnetic drive centrifugal pumps

These nonmetallic magnetic drive centrifugal pumps are ideal for low viscous chemicals. Made from either PP or PVDF, they safely handle concentrated C.I.P. chemicals.

meeting your needs with versatile

centrifugal and hose pumps

Our peristaltic pumps, PT & PTL, combine the best available materials with smart design solutions in order to maximize running time and minimize maintenance.

PT and PTL peristaltic pumps - hose pumps

The high pressure PT series allow pressures up to 15 bar, while PTL is the low pressure series with max pressure 4 bar.



PT pumps



PTL pumps

Fast Facts Peristaltic Pumps:

- Capacity PT: up to 88 m³/h (387 US gpm)
PTL: up to 10 m³/h (44 US gpm)
- Pressure PT: up to 15 bar (218 psi)
PTL: up to 4 bar (58 psi)
- Sizes PT: 5 up to 125 mm hose
PTL: 9 up to 45 mm hose
- Hose materials PT: NR, NR food (FDA), NBR, NBR food (FDA), EPDM, Hypalon, FKM
PTL: Neoprene, Norprene, Silicone, Pharmed, Hypalon, EPDM, NR, NBR

Major Benefits Peristaltic Pumps:

- Easy maintenance, hose is only worn component
- Long hose life with unique hose composition
- Great choice of food approved hose materials
- Reversible flow
- Self-priming up to 9.8 m
- Able to pump high viscous products

Tailormade pump systems

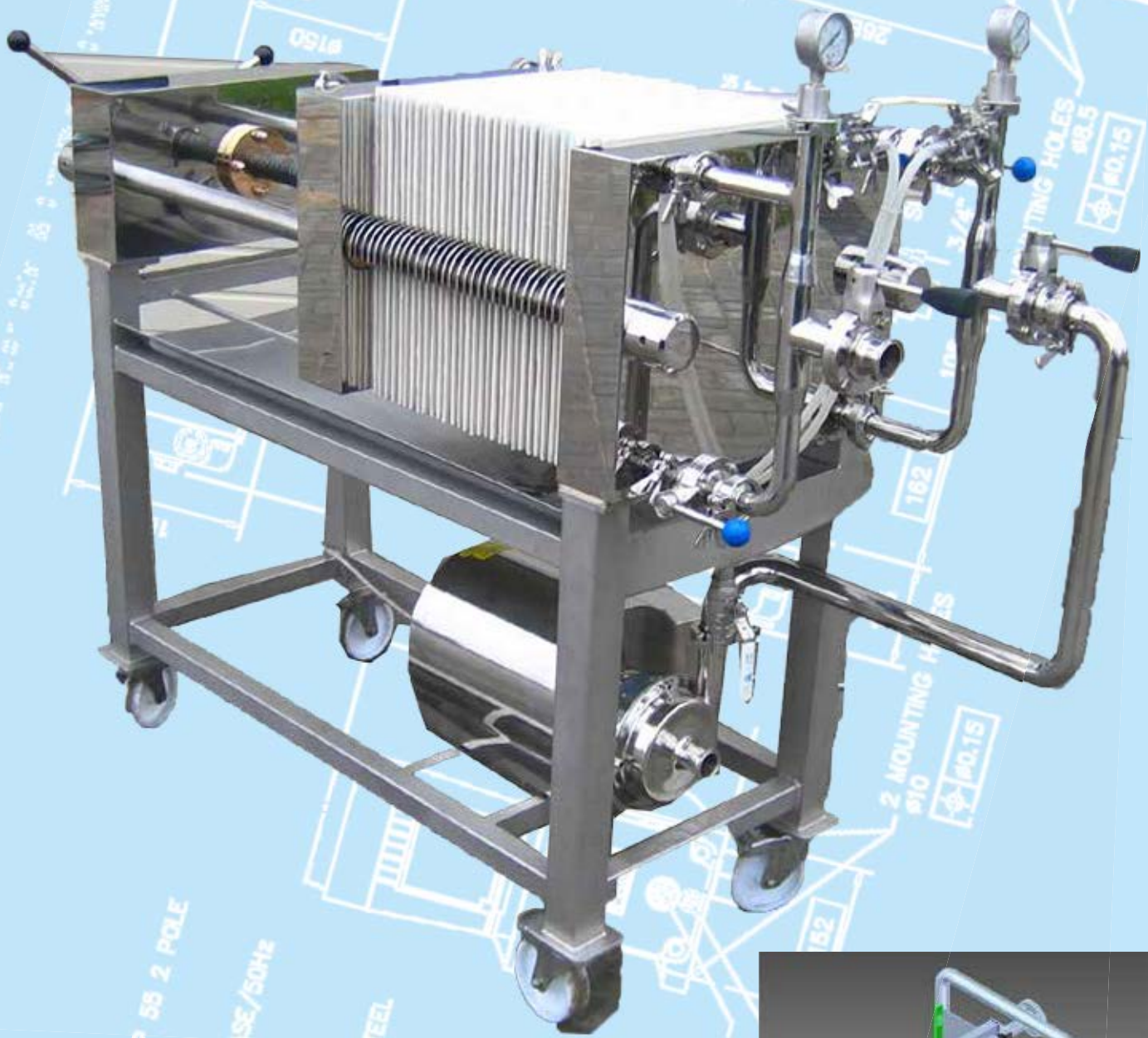

Mobile filter press unit for fruit squeezing, CTH pumps used for pumping fruit juice to storage tanks.

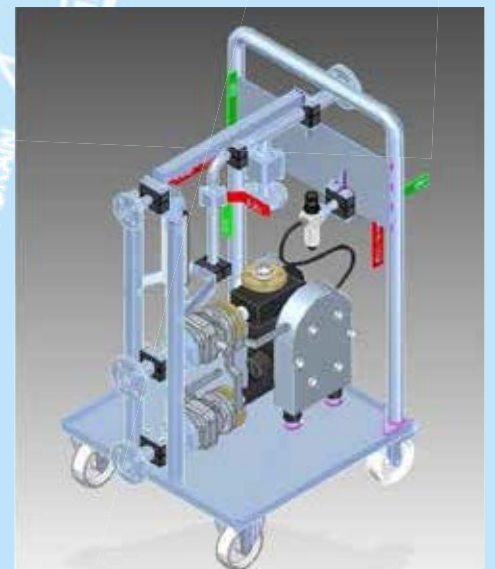

We build the whatever you need through our

engineering to order system

Engineering to Order is an engineering and manufacturing procedure which goal is to deliver specific solution desired by addressed process. In other words engineers are faced with special and most often unique problem and thereafter they try to provide adequate solution to solve or even improve proposed or existing process.

Engineering to Order is an answer to very many process optimization deliberations. Why is that? Even though we have so many products on the market there is still incomparable and unlimited number of situations where we just can't use them in the required manner. This is exactly the moment when Engineering to Order comes into play.

Where is a need people are thinking!

It is most common to apply those kinds of machinery to production/close transport facilities. However there is quite a few other possible ways of Eng. to Order application. There have been cases where one specially provided solution became standard equipment and have a potential to come into series production.

Typically Engineering to Order projects are alive and still changing until delivery time or sometimes even after. This is because we are committed to provide customer with best care possible but also we want to learn how our solutions are performing and what else can we do to improve.



GRSVENOR	
DUTY	SUITABLE FOR 2 BAR
MOTOR (STD)	100 L/MIN 400 L/HR
TYPE	3RD FRAME IP
SPEED	1500 RPM
POWER	0.38 KW
SUPPLY	415 VAC/3 PH
OPERATION	CONTINUOUS
MATERIAL	STAINLESS STEEL
FLYHEAD	STAINLESS STEEL
DIAPHRAGM	STAINLESS STEEL
TEMPERATURE	40°C MIN 150°C MAX
HEIGHT	330

MOTOR CAN BE ROTATED 90° INCREMENTS TO PROVIDE ALTERNATIVE TYPICAL 90° POSITIONS

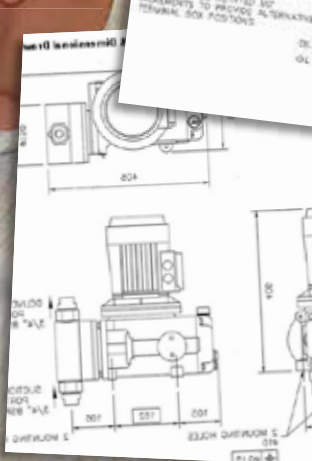

topflo®

our ambition is to

make



Tapflo evolvement in the world

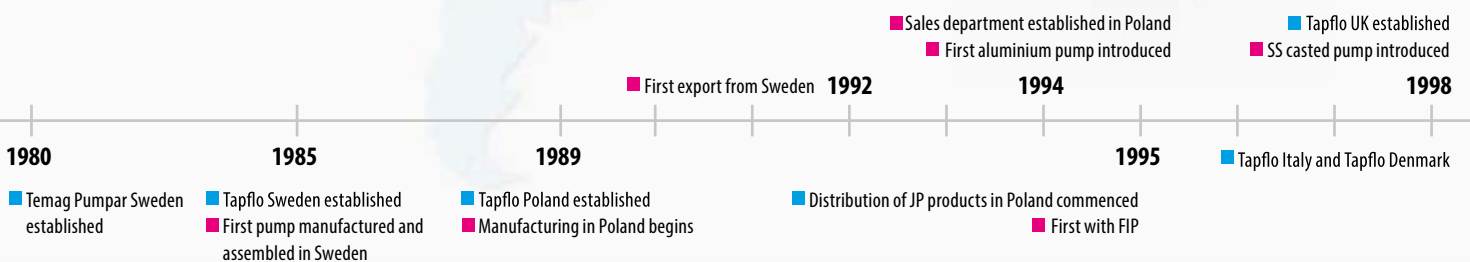

pumping easy

what ever
where ever
when ever

Tapflo is a leading pump manufacturer with the ambition to provide a wide range of premium products for various industrial applications. We are represented by Tapflo companies and distributors in more than 50 countries, with the main production located in Europe and Asia. The head quarters is situated in Sweden.

■ Long term engagement is our core

Our aim - to continue to provide first rate products according to your needs and the latest technology is mutually beneficial. That is why we see each customer relationship as a long term commitment.

■ Local means on your terms

You can summarize Tapflo's marketing philosophy with the words: We think global but act locally.

■ Flexibility - our idea of a good service

We are prepared to deal with reality, knowing that in practice this means answering questions, offering solutions and supply spare parts with a minimal loss of time.

■ Customizing the product to the needs

Our intention is always to help our clients find the most cost effective solutions to increase their company's efficiency. If this means changing the design of the pump we see it as a challenge - not a problem.

■ To produce is to develop

When you are actively involved in the manufacture of a product, it is almost impossible not to discover ways to improve it. This allows us to frequently offer pumps that are even more sustainable and efficient.

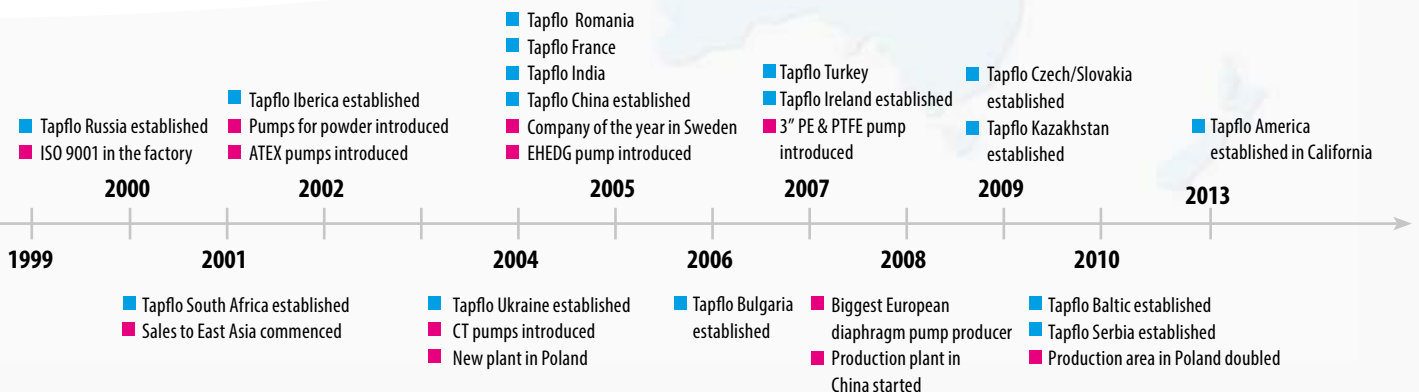

Integrated in your plant

Clean water

Clean water or so called deionized water is used (clean water free from carbon molecules) is used widely in food- a pharmaceutical processing plants. Here it is extremely important using 316L (low carbon), use of normal 316 will cause "picking" inside the pump when carbon molecules are "stolen back" by the deionized water. This will turn deionized water to normal water, the process will fail and also the pump will be destroyed. The solution is using the Tapflo CTH centrifugal pump that always come with 316L wetted materials and optionally sintered (pure) silicon carbide seals.



CIP feeding pump

CIP cleaning

CIP cleaning (Clean In Place) is an automatic cleaning system where the pipe system with its pumps, valves and other equipment is flushed with a cleaning liquid, all while the system is assembled. To obtain sufficient cleanliness, the CIP flow speed in the system is minimum 1.5 to 2.0 m/s, relatively low back pressure up to 1 bar is required. Tapflo CTH range is commonly used as CIP pump for pipe systems from 3/4" up to 4" (DN 15 up to DN 100). For the concentrated cleaning chemicals, small sized 3/8" or 1/2" plastic diaphragm pumps are typically used.



CIP preparation pump



CIP return pump

Process pump for handling hygienic liquids



SIP cleaning

SIP cleaning, Sterilize In Place is widely used in pharmaceutical industry, but becomes more and more popular also in food and beverage industries. Two methods are used for SIP, either the classic steam injection where basically no pumps are required, or liquid sterilization in closed pressurized (2 bar) system. This second method saves process equipment like pumps from dry running, saving costs and life of mechanical seals etc.

handling liquids in hygienic industries

refining your process

In your production plant there are numerous of pump applications. Main focus is probably pumps for the ready products and clean water, however there are probably just as much needs of pumps for ingredients, additives and auxiliary applications like detergents, chemicals and solvents. Whichever part of your process, we will provide the suitable pump solution.

Moving the product

The above mentioned applications are keystones in almost all food-beverage- and pharmaceutical processes. However pumping the ready product is usually the greatest challenge. The first challenge is that the nature of the product might be demanding for process equipment like pumps; high viscosity, big solids or abrasive ingredients. The second challenge is that the product shall maintain its shape and nature after the process, without any destroying of solids, shearing or contamination. For these types of duties, a cleanable pump design, selection of materials and traceability are crucial. CTH centrifugal pumps, sanitary and EHEDG diaphragms pumps and PT/PTL hose pumps are used.

ump

Application examples - food & beverage

World famous food & beverage producers as well as smaller local makers use Tapflo pumps in their processes. These two pages show a selection of them.

Kraft

Nestle

Coca Cola

Carlsberg

Unilever

Danone



Food Industry

■ Pumped media

Sugar and starch syrups – chocolate products

■ Pump

TJ125 STT sanitary pump with heating jacket

■ Application description

Transfer at ambient temperature



Food Industry

■ Pumped media

Curd chesse - dairy products

■ Pump

T425 SWT sanitary diaphragm pump

■ Application description

Filling of packing machine, 9 mm grain contents, ambient temperature



Food Industry

■ Pumped media

Vanilla custard - dairy products

■ Pump

T244 STT aseptic EHEDG diaphragm pump

■ Application description

Transfer to filling machine, ambient temperature



Food Industry

■ Pumped media

Chocolate glaze for ice cream – dairy products

■ Pump

CTH BB hygienic centrifugal pump

■ Application description

Emptying of ice cream machine

Application examples - pharmaceutical, biotech & cosmetics

Some of the most exclusive Tapflo pumps are used in multinational pharmaceutical-, biotech- and cosmetic industries. A handful of examples you find on these pages.

Glaxo Smith Kline

Pfizer

Novartis

Astra Zeneca

Eli Lilly



Pharmaceutical Industry

- **Pumped media**
Oils and ethanol
- **Pump**
T80 STT sanitary diaphragm pump
- **Application description**
Pumping from tanks, transport and dosing



Pharmaceutical Industry

- **Pumped media**
Mushroom culture organic suspension
- **Pump**
CTH CE hygienic centrifugal pump and TX30 STT sanitary diaphragm pump
- **Application description**
Unloading from fermentation process reactor (CTH pump) and emptying of mushroom culture sediments (TX30 pump)



Pharmaceutical Industry

- **Pumped media**
Solvent pumping
- **Pump**
TX120 STT industrial stainless steel diaphragm pump
- **Application description**
Mobile nit for solvent pumping, with nitrogen pipe purge system



Hygiene Products

- **Pumped media**
Shampoos and liquid soaps
- **Pump**
T125 STS sanitary diaphragm pump
- **Application description**
Transfer of shampoos and liquid soaps directly to filling machines

Product range

Fast Facts:

- Capacity 0-820 l/min (216 US gpm)
- Pressure 0 – 8 bar (116 psi)
- Sizes Sanitary 1" up to 2 1/2"
EHEDG 1 1/2" up to 2 1/2"
Plastic 1/8" up to 3"
- Materials PE, PTFE,
and stainless steel AISI 316L
(other material on request)

Major Benefits:

- Very easy to control capacity and pressure by regulating air pressure and flow
- Self-priming and able to run dry without damage
- Hygienic smooth surface and long life diaphragms
- Pollution free and non-stalling air valve



EHEDG pumps



Sanitary pumps

EHEDG aseptic diaphragm pumps

The EHEDG aseptic series AODD pumps are designed to pump food products, cosmetics or pharmaceuticals. This EHEDG (European Hygienic Engineering & Design Group) series is certified by the Danish Technological Institute and it guarantees that the design and selected materials are according to the guidelines. Apart from the design approval, the series has also been clean ability tested and approved.

The pumps are made from AISI 316L stainless steel with mirror polished surface finish Ra 0.8 (standard) or Ra 0.4 upon request. Plastics and rubbers are FDA approved and upon request USP VI approved. The pumps are designed for cleaning and sterilization in place (C.I.P. and S.I.P.).

Furthermore the manifold clamp connections and housing screws make it quick and easy to dismantle and manually clean the pumps internally. 3.1 trace ability documents will always follow when you receive your Tapflo EHEDG aseptic pump.

Sanitary pumps diaphragm pumps

This pump series is sanitary designed with wetted metal parts in electro polished stainless steel AISI 316L, with possibility of extra fine surface finish Ra 0.8. Plastics and rubbers are FDA approved. The pumps are designed for cleaning and sterilization in place (C.I.P. and S.I.P.). Furthermore the manifold clamp connections and housing screws make it quick and easy to dismantle and manually clean the pumps internally.

meeting your needs with versatile

air operated diaphragm pumps

Tapflo AODD range is extremely versatile, handling all sorts of liquid products; thin, thick, with solids, and sensitive.

Plastic diaphragm pumps

Pumps made of polyethylene (PE HD) or virgin PTFE plastics handle all kind of chemicals, in food and beverage industries they are mainly used for pumping C.I.P. chemicals. In pharmaceutical industries they handle all type of raw chemicals. The pumps are available also in explosion proof ATEX-marked versions.

PE & PTFE pumps



Metal diaphragm pumps

Molded industrial pumps in glass blast stainless steel AISI 316L, typically used for raw chemicals, solvents and waste applications. The pumps are available also in explosion proof ATEX-marked versions.

Available options:

- Heating jacket is available on the sanitary pumps, typically used in chocolate and glaze applications
- Flap valves is an option on sanitary pumps, the perfect solution for gentle pumping of big size solids up to 48 mm.
- Pneumatic systems are available for all our diaphragm pumps, adding increased safety by automatic control and monitoring:
 - Diaphragm rupture guardian system
 - Level control
 - Dead head and dry run guardian system
 - Start & start units
 - Batch control



Metal pumps

Sanitary active pulsation dampeners:

The sanitary series of Tapflo dampeners has been designed in particular for food, beverage, pharmaceutical and cosmetic industries where cleanliness and sterile environment is necessary.

Made to be clean

The dampener is designed and prepared for cleaning and sterilization in place – C.I.P. and S.I.P. These are automatic cleaning and disinfection procedures implemented in these industries so it is essential that our product are prepared to comply with these procedures.



Product range

Fast Facts Centrifugal Pumps:

- Capacity 0-60 m³/h (264 US gpm)
- Head 2 – 47 m (154 ft)
- Sizes ¾" up to 2 ½", 0.12– 11 kW
- Materials PP, PVDF and stainless steel
AISI 316L

Major Benefits Centrifugal Pumps:

- The centrifugal principle gives a very high capacity
- Pumps made from AISI 316L, ideal for any food contact applications
- Big choice of sealing face materials
- Many options available, see below

Our centrifugal pumps are very efficient, pumping low and medium viscous liquids with high capacity in relation to the size of the pumps. Mechanical sealed pumps in stainless steel, as well as seal less pumps in plastics PP and PVDF are available.



CTH pumps

CTH centrifugal pumps

This hygienic single mechanical sealed pump series is supplied with electro polished Ra 0.8 pump casing and internals. This pump series is especially dedicated for hygienic duties in food and beverage industries. A wide range of sealing face materials are available – ceramic, graphite, SiC and with o-rings in FDA approved EPDM, FKM or FEP.

A number of special executions are available:

- Heating jacket – Great protection for the mechanical seal in applications with risk of solidification, example chocolate glaze, paraffin, starch, glucose syrup and margarine etc.
- Hygienic shroud – Easier to keep the pump externals clean, protects the motor from spraying water.
- Casing drainage – By positioning the outlet horizontal at the bottom, or by means of a drain connection the pump features a hygienic and automatic draining.
- Long coupled – The perfect solution for hot products like eatable oils



CTM pumps

CTM magnetic drive centrifugal pumps

These nonmetallic magnetic drive centrifugal pumps are ideal for low viscous chemicals. Made from either PP or PVDF, they safely handle concentrated C.I.P. chemicals.

meeting your needs with versatile

centrifugal and hose pumps

Our peristaltic pumps, PT & PTL, combine the best available materials with smart design solutions in order to maximize running time and minimize maintenance.

PT and PTL peristaltic pumps - hose pumps

The high pressure PT series allow pressures up to 15 bar, while PTL is the low pressure series with max pressure 4 bar.



PT pumps



PTL pumps

Fast Facts Peristaltic Pumps:

- Capacity PT: up to 88 m³/h (387 US gpm)
PTL: up to 10 m³/h (44 US gpm)
- Pressure PT: up to 15 bar (218 psi)
PTL: up to 4 bar (58 psi)
- Sizes PT: 5 up to 125 mm hose
PTL: 9 up to 45 mm hose
- Hose materials PT: NR, NR food (FDA), NBR, NBR food (FDA), EPDM, Hypalon, FKM
PTL: Neoprene, Norprene, Silicone, Pharmed, Hypalon, EPDM, NR, NBR

Major Benefits Peristaltic Pumps:

- Easy maintenance, hose is only worn component
- Long hose life with unique hose composition
- Great choice of food approved hose materials
- Reversible flow
- Self-priming up to 9.8 m
- Able to pump high viscous products

Tailormade pump systems

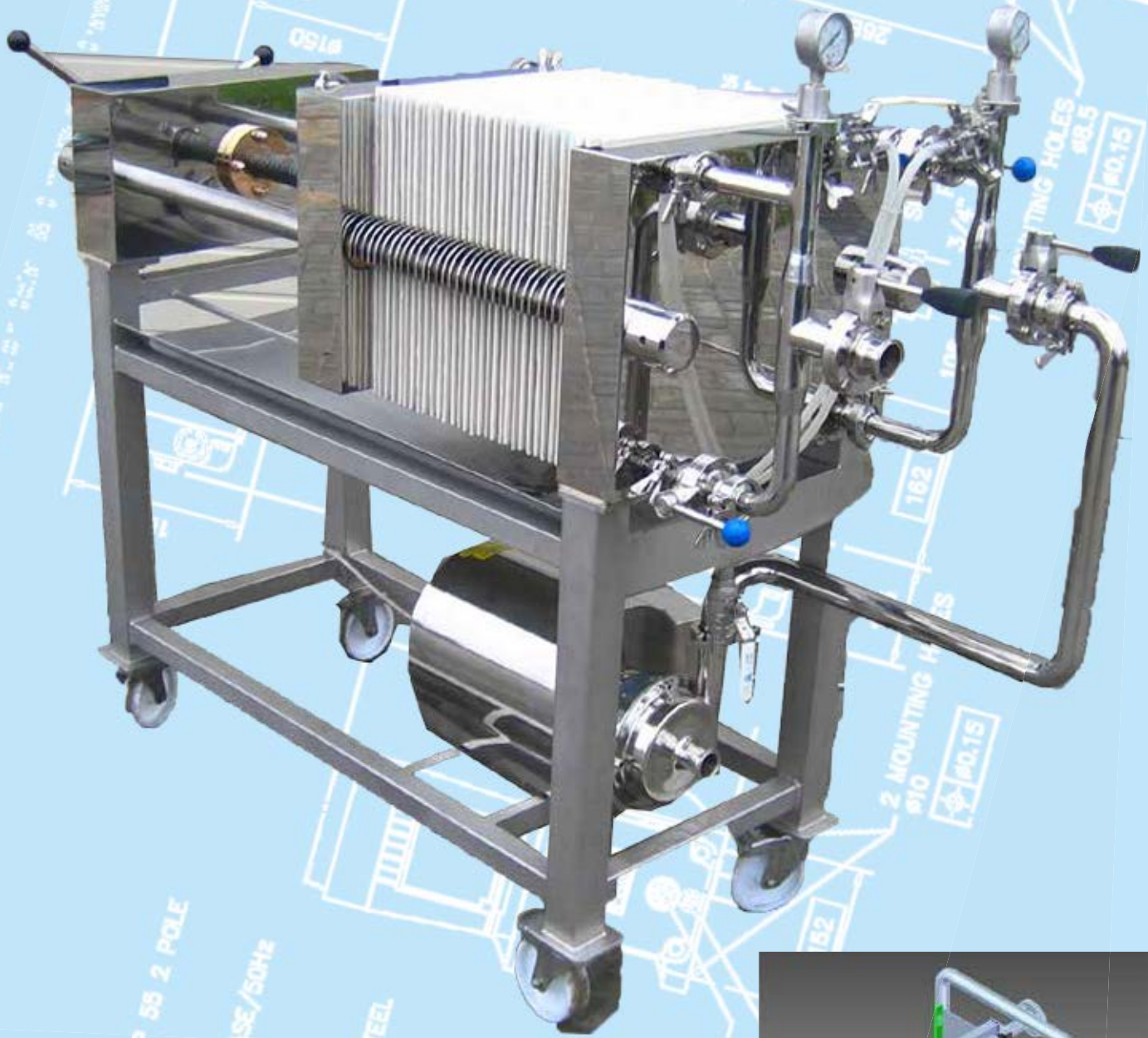

Mobile filter press unit for fruit squeezing, CTH pumps used for pumping fruit juice to storage tanks.

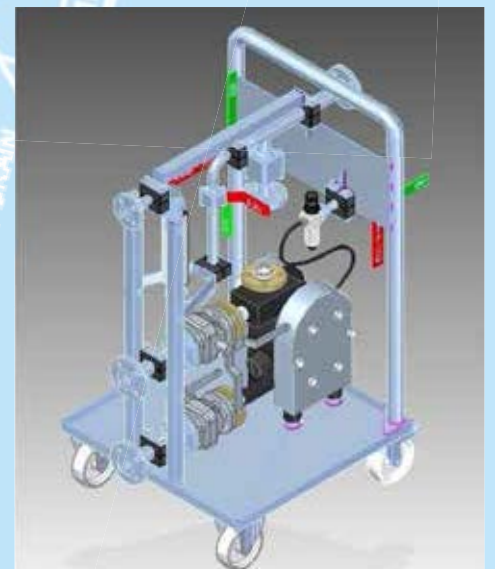

We build the whatever you need through our

engineering to order system

Engineering to Order is an engineering and manufacturing procedure which goal is to deliver specific solution desired by addressed process. In other words engineers are faced with special and most often unique problem and thereafter they try to provide adequate solution to solve or even improve proposed or existing process.

Engineering to Order is an answer to very many process optimization deliberations. Why is that? Even though we have so many products on the market there is still incomparable and unlimited number of situations where we just can't use them in the required manner. This is exactly the moment when Engineering to Order comes into play.

Where is a need people are thinking!

It is most common to apply those kinds of machinery to production/close transport facilities. However there is quite a few other possible ways of Eng. to Order application. There have been cases where one specially provided solution became standard equipment and have a potential to come into series production.

Typically Engineering to Order projects are alive and still changing until delivery time or sometimes even after. This is because we are committed to provide customer with best care possible but also we want to learn how our solutions are performing and what else can we do to improve.



GRANVENOR	
DUTY	SUBC00-0
	0 BAK
	0 BAR
	100 L/MH
	800 L/20H
MOTOR (STD)	
TYPE	380 FRAME IP
SPEED	1500 RPM
POWER	0.55 KW
SUPPLY	415 VAC/3 PH
OPERATION	CONTINUOUS
MATERIAL	MATERIAL
FLYHEAD	STL STABILIZED
SHAFT	Ø 16
TEMPERATURE	40 °C MIN
	50 °C MAX - 40 °C
	70 °C MAX - 200 °C
HEIGHT	350
MOTOR CAN BE ROTATED 60° INCREMENTS TO PROVIDE ALTERNATIVE TORSIONAL SOB POSITIONS	

topflo®

our ambition is to

make



Tapflo evolvement in the world

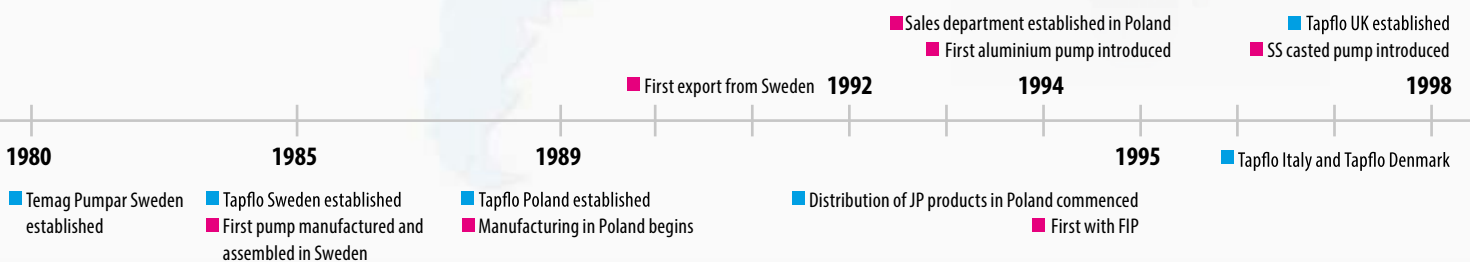

pumping easy

what ever
where ever
when ever

Tapflo is a leading pump manufacturer with the ambition to provide a wide range of premium products for various industrial applications. We are represented by Tapflo companies and distributors in more than 50 countries, with the main production located in Europe and Asia. The head quarters is situated in Sweden.

■ Long term engagement is our core

Our aim - to continue to provide first rate products according to your needs and the latest technology is mutually beneficial. That is why we see each customer relationship as a long term commitment.

■ Local means on your terms

You can summarize Tapflo's marketing philosophy with the words: We think global but act locally.

■ Flexibility - our idea of a good service

We are prepared to deal with reality, knowing that in practice this means answering questions, offering solutions and supply spare parts with a minimal loss of time.

■ Customizing the product to the needs

Our intention is always to help our clients find the most cost effective solutions to increase their company's efficiency. If this means changing the design of the pump we see it as a challenge - not a problem.

■ To produce is to develop

When you are actively involved in the manufacture of a product, it is almost impossible not to discover ways to improve it. This allows us to frequently offer pumps that are even more sustainable and efficient.

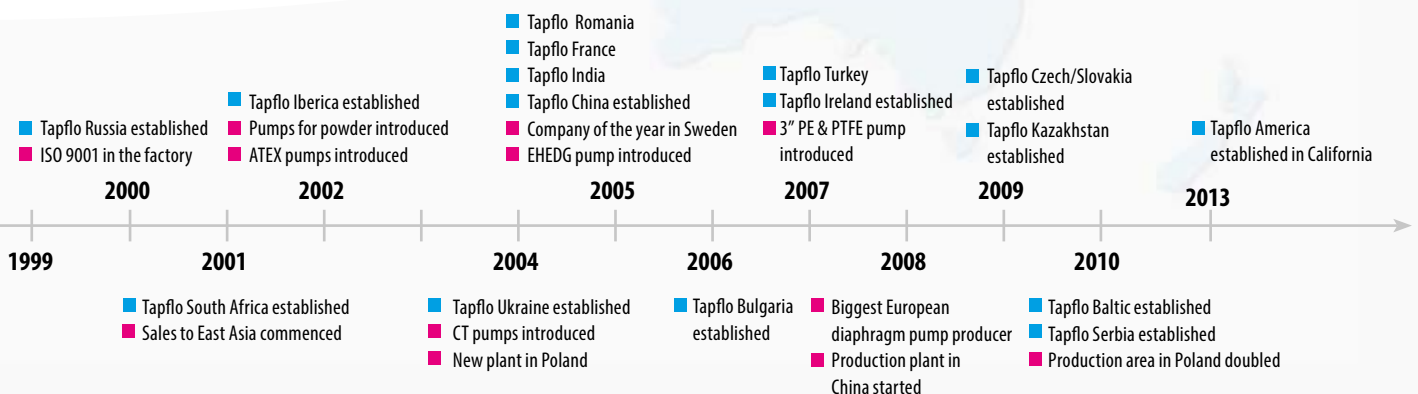

handling liquids in hygienic industries

refining your process

In your production plant there are numerous of pump applications. Main focus is probably pumps for the ready products and clean water, however there are probably just as much needs of pumps for ingredients, additives and auxiliary applications like detergents, chemicals and solvents. Whichever part of your process, we will provide the suitable pump solution.

Moving the product

The above mentioned applications are keystones in almost all food-beverage- and pharmaceutical processes. However pumping the ready product is usually the greatest challenge. The first challenge is that the nature of the product might be demanding for process equipment like pumps; high viscosity, big solids or abrasive ingredients. The second challenge is that the product shall maintain its shape and nature after the process, without any destroying of solids, shearing or contamination. For these types of duties, a cleanable pump design, selection of materials and traceability are crucial. CTH centrifugal pumps, sanitary and EHEDG diaphragms pumps and PT/PTL hose pumps are used.

ump

Application examples - food & beverage

World famous food & beverage producers as well as smaller local makers use Tapflo pumps in their processes. These two pages show a selection of them.

Kraft

Nestle

Coca Cola

Carlsberg

Unilever

Danone



Food Industry

■ Pumped media

Sugar and starch syrups – chocolate products

■ Pump

TJ125 STT sanitary pump with heating jacket

■ Application description

Transfer at ambient temperature



Food Industry

■ Pumped media

Curd chesse - dairy products

■ Pump

T425 SWT sanitary diaphragm pump

■ Application description

Filling of packing machine, 9 mm grain contents, ambient temperature



Food Industry

■ Pumped media

Vanilla custard - dairy products

■ Pump

T244 STT aseptic EHEDG diaphragm pump

■ Application description

Transfer to filling machine, ambient temperature



Food Industry

■ Pumped media

Chocolate glaze for ice cream – dairy products

■ Pump

CTH BB hygienic centrifugal pump

■ Application description

Emptying of ice cream machine

Application examples - pharmaceutical, biotech & cosmetics

Some of the most exclusive Tapflo pumps are used in multinational pharmaceutical-, biotech- and cosmetic industries. A handful of examples you find on these pages.

Glaxo Smith Kline

Pfizer

Novartis

Astra Zeneca

Eli Lilly



Pharmaceutical Industry

- **Pumped media**
Oils and ethanol
- **Pump**
T80 STT sanitary diaphragm pump
- **Application description**
Pumping from tanks, transport and dosing



Pharmaceutical Industry

- **Pumped media**
Mushroom culture organic suspension
- **Pump**
CTH CE hygienic centrifugal pump and TX30 STT sanitary diaphragm pump
- **Application description**
Unloading from fermentation process reactor (CTH pump) and emptying of mushroom culture sediments (TX30 pump)

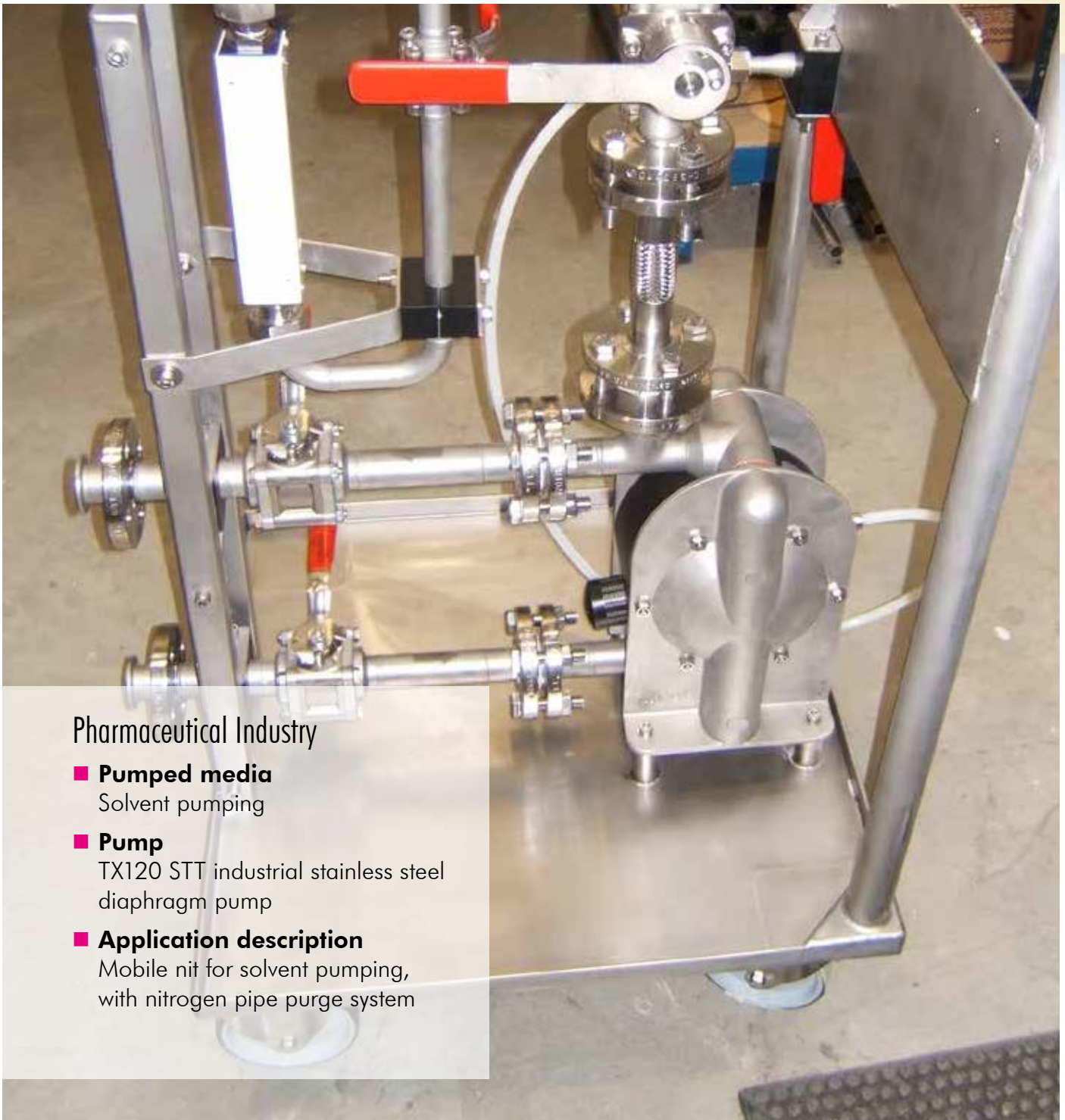

Pharmaceutical Industry

- **Pumped media**
Solvent pumping
- **Pump**
TX120 STT industrial stainless steel diaphragm pump
- **Application description**
Mobile nit for solvent pumping, with nitrogen pipe purge system



Hygiene Products

- **Pumped media**
Shampoos and liquid soaps
- **Pump**
T125 STS sanitary diaphragm pump
- **Application description**
Transfer of shampoos and liquid soaps directly to filling machines

Product range

Fast Facts:

- Capacity 0-820 l/min (216 US gpm)
- Pressure 0 – 8 bar (116 psi)
- Sizes Sanitary 1" up to 2 1/2"
EHEDG 1 1/2" up to 2 1/2"
Plastic 1/8" up to 3"
- Materials PE, PTFE,
and stainless steel AISI 316L
(other material on request)

Major Benefits:

- Very easy to control capacity and pressure by regulating air pressure and flow
- Self-priming and able to run dry without damage
- Hygienic smooth surface and long life diaphragms
- Pollution free and non-stalling air valve



EHEDG pumps



Sanitary pumps

EHEDG aseptic diaphragm pumps

The EHEDG aseptic series AODD pumps are designed to pump food products, cosmetics or pharmaceuticals. This EHEDG (European Hygienic Engineering & Design Group) series is certified by the Danish Technological Institute and it guarantees that the design and selected materials are according to the guidelines. Apart from the design approval, the series has also been clean ability tested and approved.

The pumps are made from AISI 316L stainless steel with mirror polished surface finish Ra 0.8 (standard) or Ra 0.4 upon request. Plastics and rubbers are FDA approved and upon request USP VI approved. The pumps are designed for cleaning and sterilization in place (C.I.P. and S.I.P.).

Furthermore the manifold clamp connections and housing screws make it quick and easy to dismantle and manually clean the pumps internally. 3.1 trace ability documents will always follow when you receive your Tapflo EHEDG aseptic pump.

Sanitary pumps diaphragm pumps

This pump series is sanitary designed with wetted metal parts in electro polished stainless steel AISI 316L, with possibility of extra fine surface finish Ra 0.8. Plastics and rubbers are FDA approved. The pumps are designed for cleaning and sterilization in place (C.I.P. and S.I.P.). Furthermore the manifold clamp connections and housing screws make it quick and easy to dismantle and manually clean the pumps internally.

meeting your needs with versatile

air operated diaphragm pumps

Tapflo AODD range is extremely versatile, handling all sorts of liquid products; thin, thick, with solids, and sensitive.

Plastic diaphragm pumps

Pumps made of polyethylene (PE HD) or virgin PTFE plastics handle all kind of chemicals, in food and beverage industries they are mainly used for pumping C.I.P. chemicals. In pharmaceutical industries they handle all type of raw chemicals. The pumps are available also in explosion proof ATEX-marked versions.

PE & PTFE pumps



Metal diaphragm pumps

Molded industrial pumps in glass blast stainless steel AISI 316L, typically used for raw chemicals, solvents and waste applications. The pumps are available also in explosion proof ATEX-marked versions.

Available options:

- Heating jacket is available on the sanitary pumps, typically used in chocolate and glaze applications
- Flap valves is an option on sanitary pumps, the perfect solution for gentle pumping of big size solids up to 48 mm.
- Pneumatic systems are available for all our diaphragm pumps, adding increased safety by automatic control and monitoring:
 - Diaphragm rupture guardian system
 - Level control
 - Dead head and dry run guardian system
 - Start & start units
 - Batch control



Metal pumps

Sanitary active pulsation dampeners:

The sanitary series of Tapflo dampeners has been designed in particular for food, beverage, pharmaceutical and cosmetic industries where cleanliness and sterile environment is necessary.

Made to be clean

The dampener is designed and prepared for cleaning and sterilization in place – C.I.P. and S.I.P. These are automatic cleaning and disinfection procedures implemented in these industries so it is essential that our product are prepared to comply with these procedures.



Product range

Fast Facts Centrifugal Pumps:

- Capacity 0-60 m³/h (264 US gpm)
- Head 2 – 47 m (154 ft)
- Sizes ¾" up to 2 ½", 0.12– 11 kW
- Materials PP, PVDF and stainless steel
AISI 316L

Major Benefits Centrifugal Pumps:

- The centrifugal principle gives a very high capacity
- Pumps made from AISI 316L, ideal for any food contact applications
- Big choice of sealing face materials
- Many options available, see below

Our centrifugal pumps are very efficient, pumping low and medium viscous liquids with high capacity in relation to the size of the pumps. Mechanical sealed pumps in stainless steel, as well as seal less pumps in plastics PP and PVDF are available.



CTH pumps

CTH centrifugal pumps

This hygienic single mechanical sealed pump series is supplied with electro polished Ra 0.8 pump casing and internals. This pump series is especially dedicated for hygienic duties in food and beverage industries. A wide range of sealing face materials are available – ceramic, graphite, SiC and with o-rings in FDA approved EPDM, FKM or FEP.

A number of special executions are available:

- Heating jacket – Great protection for the mechanical seal in applications with risk of solidification, example chocolate glaze, paraffin, starch, glucose syrup and margarine etc.
- Hygienic shroud – Easier to keep the pump externals clean, protects the motor from spraying water.
- Casing drainage – By positioning the outlet horizontal at the bottom, or by means of a drain connection the pump features a hygienic and automatic draining.
- Long coupled – The perfect solution for hot products like eatable oils



CTM pumps

CTM magnetic drive centrifugal pumps

These nonmetallic magnetic drive centrifugal pumps are ideal for low viscous chemicals. Made from either PP or PVDF, they safely handle concentrated C.I.P. chemicals.

meeting your needs with versatile

centrifugal and hose pumps

Our peristaltic pumps, PT & PTL, combine the best available materials with smart design solutions in order to maximize running time and minimize maintenance.

PT and PTL peristaltic pumps - hose pumps

The high pressure PT series allow pressures up to 15 bar, while PTL is the low pressure series with max pressure 4 bar.



PT pumps



PTL pumps

Fast Facts Peristaltic Pumps:

- Capacity PT: up to 88 m³/h (387 US gpm)
PTL: up to 10 m³/h (44 US gpm)
- Pressure PT: up to 15 bar (218 psi)
PTL: up to 4 bar (58 psi)
- Sizes PT: 5 up to 125 mm hose
PTL: 9 up to 45 mm hose
- Hose materials PT: NR, NR food (FDA), NBR, NBR food (FDA), EPDM, Hypalon, FKM
PTL: Neoprene, Norprene, Silicone, Pharmed, Hypalon, EPDM, NR, NBR

Major Benefits Peristaltic Pumps:

- Easy maintenance, hose is only worn component
- Long hose life with unique hose composition
- Great choice of food approved hose materials
- Reversible flow
- Self-priming up to 9.8 m
- Able to pump high viscous products

Tailormade pump systems

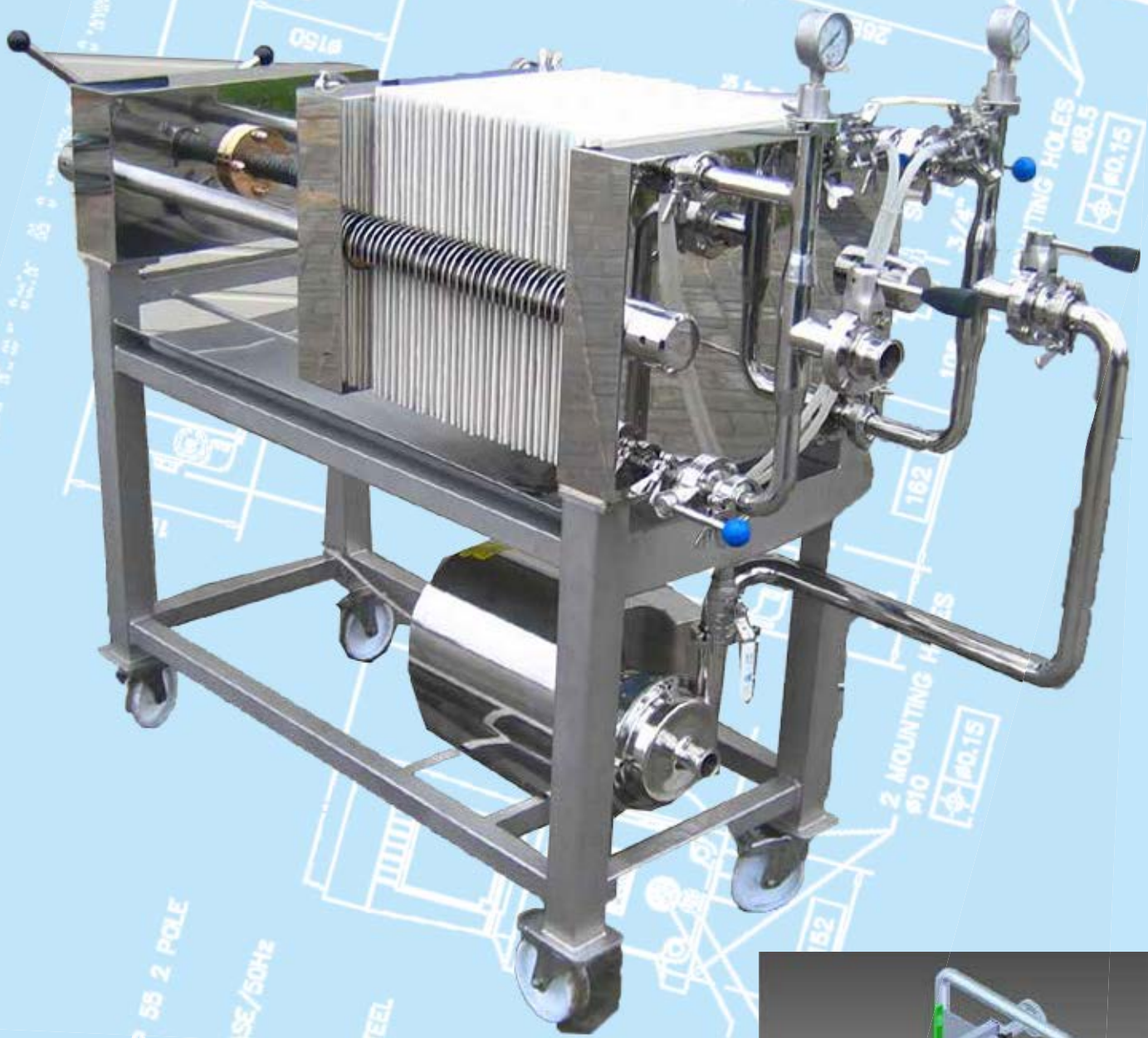

Mobile filter press unit for fruit squeezing, CTH pumps used for pumping fruit juice to storage tanks.

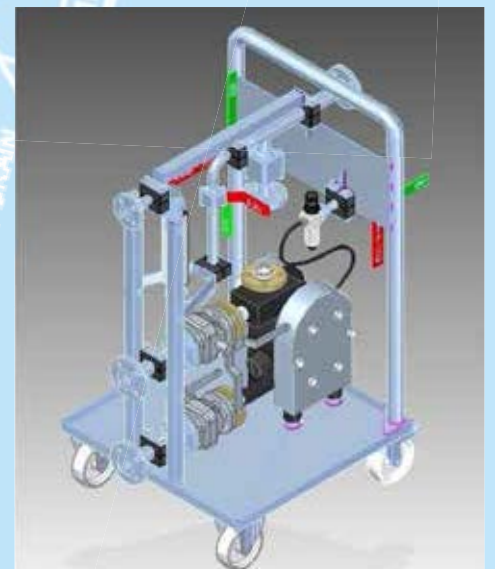

We build the whatever you need through our

engineering to order system

Engineering to Order is an engineering and manufacturing procedure which goal is to deliver specific solution desired by addressed process. In other words engineers are faced with special and most often unique problem and thereafter they try to provide adequate solution to solve or even improve proposed or existing process.

Engineering to Order is an answer to very many process optimization deliberations. Why is that? Even though we have so many products on the market there is still incomparable and unlimited number of situations where we just can't use them in the required manner. This is exactly the moment when Engineering to Order comes into play.

Where is a need people are thinking!

It is most common to apply those kinds of machinery to production/close transport facilities. However there is quite a few other possible ways of Eng. to Order application. There have been cases where one specially provided solution became standard equipment and have a potential to come into series production.

Typically Engineering to Order projects are alive and still changing until delivery time or sometimes even after. This is because we are committed to provide customer with best care possible but also we want to learn how our solutions are performing and what else can we do to improve.

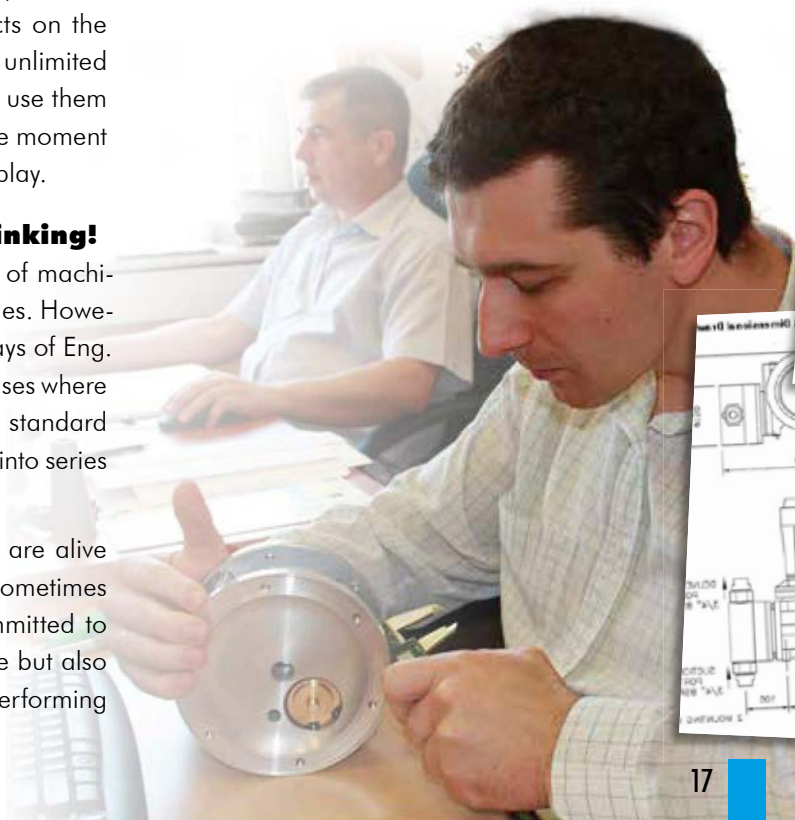

PARAMETER	VALUE
DUTY	SUBC00-0
0 BAK	100 L/MH
0 BAR	0.33 L/0.08
MOTOR (STD)	
TYPE	3RD FRAME IP
SPEED	1500 RPM
POWER	0.33 kW
SUPPLY	415 VAC/3 PH
OPERATION	CONTINUOUS
MATERIAL	STAINLESS
FLYHEAD	STAINLESS
DIAPHRAGM	STAINLESS
TEMPERATURE	40°C MIN 50°C MAX - 40°C 70°C MAX - 200L
HEIGHT	330

MOTOR CAN BE ROTATED 60°
INCREMENTS TO PROVIDE ALTERNATIVE
TORSION SOB POSITIONS

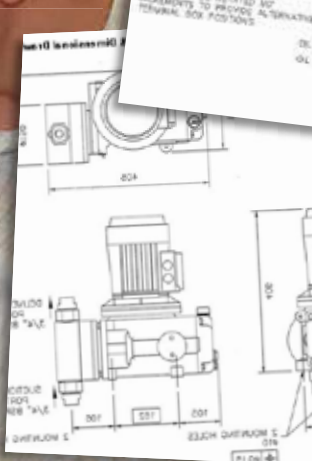

topflo®

our ambition is to

make



Tapflo evolvement in the world

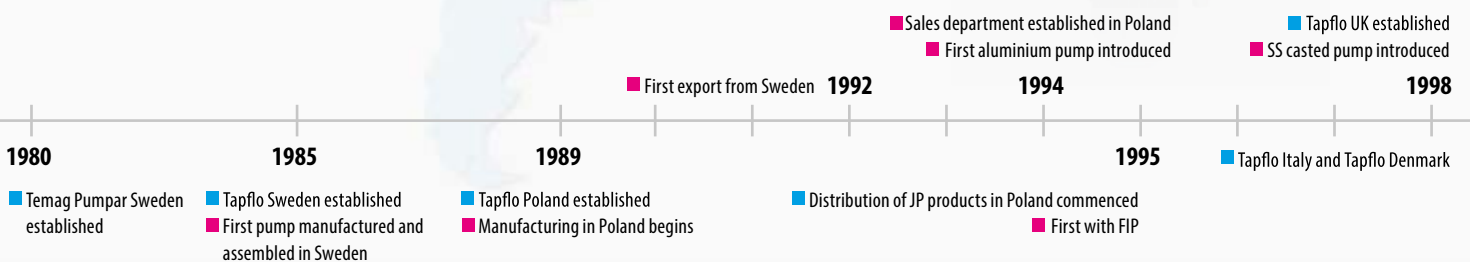

pumping easy

what ever
where ever
when ever

Tapflo is a leading pump manufacturer with the ambition to provide a wide range of premium products for various industrial applications. We are represented by Tapflo companies and distributors in more than 50 countries, with the main production located in Europe and Asia. The head quarters is situated in Sweden.

■ Long term engagement is our core

Our aim - to continue to provide first rate products according to your needs and the latest technology is mutually beneficial. That is why we see each customer relationship as a long term commitment.

■ Local means on your terms

You can summarize Tapflo's marketing philosophy with the words: We think global but act locally.

■ Flexibility - our idea of a good service

We are prepared to deal with reality, knowing that in practice this means answering questions, offering solutions and supply spare parts with a minimal loss of time.

■ Customizing the product to the needs

Our intention is always to help our clients find the most cost effective solutions to increase their company's efficiency. If this means changing the design of the pump we see it as a challenge - not a problem.

■ To produce is to develop

When you are actively involved in the manufacture of a product, it is almost impossible not to discover ways to improve it. This allows us to frequently offer pumps that are even more sustainable and efficient.

