

IOM manual

tapflo®

DT Series Active Pulsation Dampeners

2015 rev 1



**Read this instruction manual carefully,
before you install and operate the pump**



**Active pulsation dampeners
models:**

DT 9/20/25
DT 50/70/80
DT 100/120/125
DT 200/220/225
DT 400/420/425
DT 800/820/825



» All about your flow

www.tapflo.com



0.	GENERAL	4
0.1.	Introduction	4
0.2.	Warning symbols	4
1.	INSTALLATION & SAFETY	5
1.1.	Receiving inspection	5
1.2.	Storage	5
1.3.	Installation of the dampener	5
1.4.	Operation principal	6
1.5.	Health & Safety	6
1.5.1.	Protection	7
1.5.2.	Explosion hazardous environments – ATEX	7
1.5.3.	Air pressure	7
1.5.4.	Noise level	7
1.5.5.	Temperature hazards	7
2.	MAINTENANCE	8
2.1.	When dampener is new or re-assembled	8
2.2.	Routine inspection	8
2.3.	Location of faults	8
2.4.	Dismantling of the dampener	8
2.5.	Assembling the dampener	10
3.	SPARE PARTS	13
3.1.	Spare parts drawing – PE, PTFE and aluminium	13
3.2.	Spare parts list – PE, PTFE and aluminium	13
3.3.	Spare parts drawing – steel and sanitary	14
3.4.	Spare parts list – steel and sanitary	14
3.5.	Recommended spare parts	15
3.6.	How to order parts	15
4.	TECHNICAL DATA	16
4.1.	Dimensions	16
4.2.	Tightening torques	17
4.3.	Dampener code	17
5.	WARRANTY & REPAIR	18
5.1.	Returning parts	18
5.2.	Warranty	18
5.3.	Warranty form	20



Declaration of conformity

Machinery directive 2006/42/EC

Tapflo AB declares that:

Product name: **Active Pulsation Damener**
Models: **D T...**

Is in conformity with the essential health and safety requirements and technical construction file requirements of the EC Machinery directive 2006/42/EC.

Manufacturer: **Tapflo AB**

Address: **Filaregatan 4**
S-442 34 Kungälv
Sweden

Tapflo AB, January 1:st 2014

Håkan Ekstrand
Managing director



0.1 Introduction

The active pulsation dampener is the most efficient way to remove pressure variations on the discharge of the pump. The Tapflo pulsation dampener works actively with compressed air and a diaphragm, automatically setting the correct pressure to minimise the pulsations. The pulsation dampener is available for all Tapflo pump sizes and material versions.

With proper attention to maintenance, Tapflo active pulsation dampeners will give efficient and trouble free operation. This instruction manual will familiarise operators with detailed information about installing, operating and maintaining the dampener.

0.2 The warning symbols

The following warning symbols are present in this instruction manual. This is what they say.



This symbol stands next to all safety instructions in this instruction manual where danger to life and limb may occur. Observe these instructions and proceed with utmost caution in these situations. Inform also other users of all safety instructions. In addition to the instructions in this instruction manual, the general safety and accident prevention regulations must be observed.



This signal stands at points in this instruction manual of particular importance for compliance with regulations and directives, for correct work flow and for the prevention of damage and destruction of the complete dampener or its subassemblies.

1. INSTALLATION & SAFETY



1.1 Receiving inspection

Although precaution is taken by us when packing and shipping, we urge you to carefully check the shipment on receipt. Make sure that all parts and accessories listed on the packing list are accounted for. Immediately report any damage or shortage to the transport company and to us.

1.2 Storage



If the equipment is to be stored prior to installation, place it in a clean location. Do not remove the protective covers from the suction, discharge and air connections which have been fastened to keep pump internals free of debris. Clean the dampener thoroughly before installation.

1.3. Installation of the dampener



The pulsation dampener is installed according to the sketch. It can be connected with a nipple immediately after the pump outlet, or placed independent of the pump with a flexible hose between the pump and the dampener. Make sure that the dampener does not cause any tension or strain to the pump. The air hose is connected to the pump air hose with a T-connection, between the pump and regulator / valves (See sketch). It is important that the air to the dampener must have the same flow and pressure as to the pump!

In order to ensure the most effective pulsation dampening the dampener should be installed not further than five times the diameter of the pipeline from the discharge flange of the pump - $L < 5 * \varnothing$.

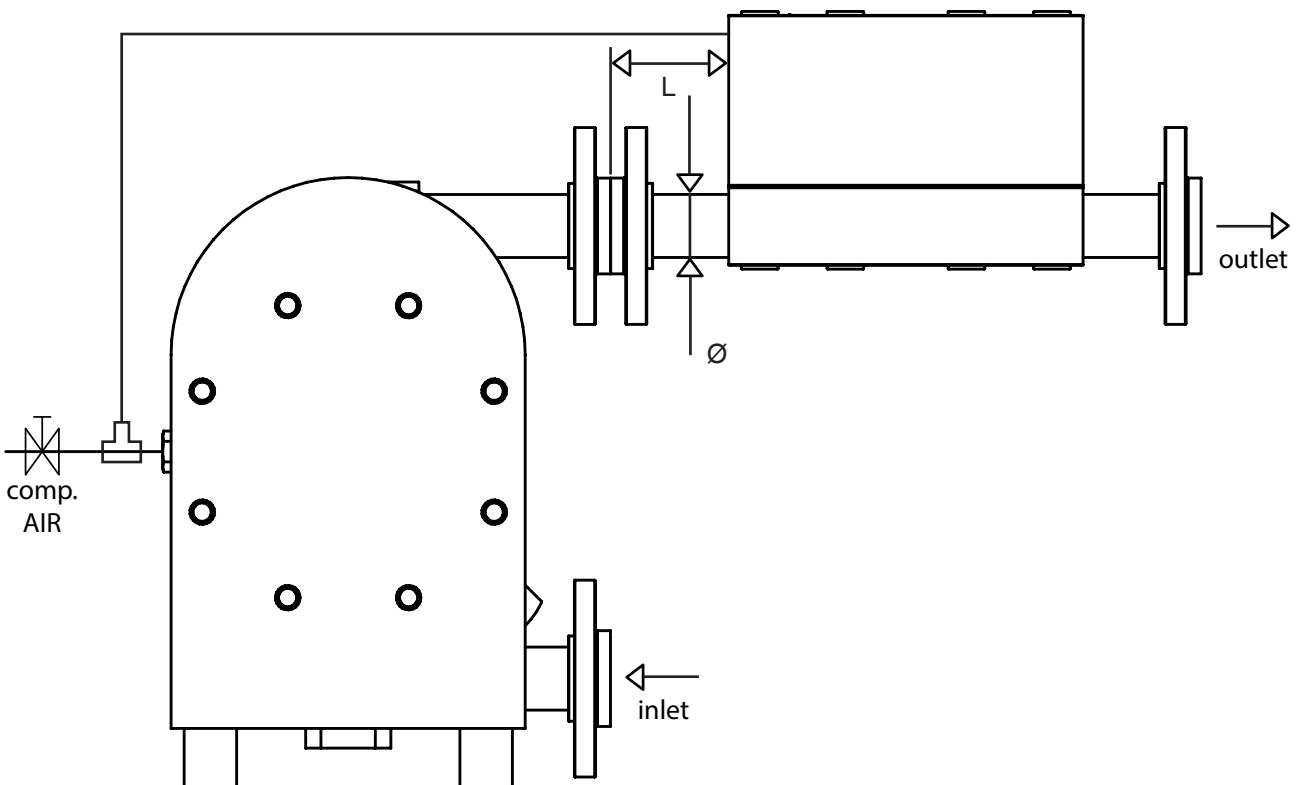

1. INSTALLATION & SAFETY



1.4 Operation principal

The pulsation dampener's main function is to remove pressure variations on the discharge of the pump. The dampener works actively with compressed air and a diaphragm, automatically setting the correct pressure to minimise the pulsations.

The air pressure supplied to the dampener is the same as the one supplied to the pump. The medium flowing through the dampener affects the diaphragm, which by means of the compressed air on the air side compensates the fluctuations of pressure in the discharge line. The air concentrated in the dampeners block works as a spring for the medium flowing through the dampener.

Before starting the pump and dampener.

- Make sure the pump is installed according to the installation instruction.

- When installation is new or re-installed, a test run should be conducted to make sure the dampener operates normally and does not leak.

- When installation is new or re-installed, check the dampener housing nut tightening torque. After approx. 1 week of operation, the torque should be checked again. This is important to prevent leakage.

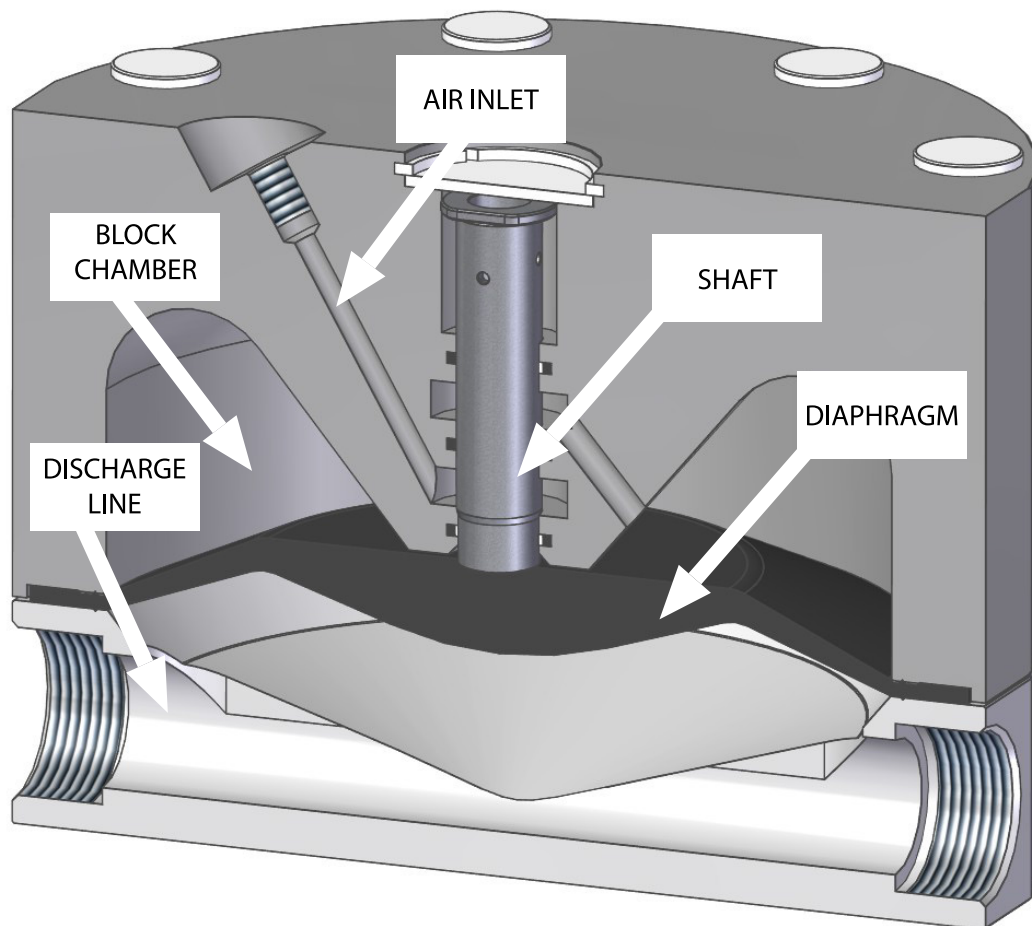

1.5 Health & Safety



The dampener must be installed according to local and national safety rules.

The dampeners are constructed for particular applications. Do not use the dampener on applications different from that for which it was sold without consulting Tapflo AB to ascertain its suitability.

1. INSTALLATION & SAFETY



1.5.1. Protection



In the interest of health and safety it is essential to wear protective clothing and safety goggles when operating, and/or working in the vicinity of Tapflo dampeners.

1.5.2. Explosion hazardous environments – ATEX



Static electricity may occur in the pump under operation, which may cause explosion and injury. Special conductive pulsation dampeners DTX are available for such applications. Follow below instructions and local/national rules for safe use.

ATEX (directive 94/9/EC) classification of Tapflo DTX dampeners:

ATEX II 2 GD IIB c T4

Equipment group **II** – all other explosive areas than mines;

Category group **2** – high level of protection (can be used in zone 1);

Atmosphere **G** – gas; **D** – dust;

Explosion group **IIB** – such as ethylene;

Type of protection **c** – constructional safety;

Temperature class **T4** – in the event of a malfunction, the maximum temperature of a surface that may be exposed to gas T4 = 135 °C.

Earth connection of dampener and other equipment

Connect a suitable earth wire to the stainless steel earth connection that is placed on the inside of one of the pump housings. Connect the other end of the earth wire to earth and also make sure that other equipment like hoses/pipes/containers etc. are properly earthed/connected.

1.5.3. Air pressure



The maximum air pressure for Tapflo dampeners is 14 bar. Higher air pressure than 14 bar can damage the dampener and may cause injury to personnel in vicinity of the dampener.

Please make sure that supply air to the dampener must have the same flow and pressure as the pump that dampener is installed with.

1.5.4. Noise level

At tests, the noise level from a Tapflo dampener has not exceeded 70 dB(A).

1.5.5. Temperature hazards

Raised temperature can cause damage to the dampener and/or piping and may also be hazardous for personnel in the vicinity of the dampener/piping. Avoid quick temperature changes and do not exceed the maximum temperature specified when the dampener was ordered.

2. MAINTENANCE



2.1. When dampener is new or re-assembled



If the dampener is new or re-assembled after maintenance it is important to re-tighten the dampener housing screws (pos. 37) after a few days of operation. Make sure to use the right torque, see chapter 4.2.

2.2. Routine inspection



Frequent observation of the dampener operation is recommended to detect problems. A change in sound of the running dampener can be an indication of wear. Leakage of liquid from the dampener and changes in performance may also be detected. Routine inspections should be conducted frequently.

2.3. Location of faults

PROBLEM	POSSIBLE FAULT
The dampener does not work	The air connection is blocked The diaphragm is damaged The muffler is blocked There is dirt in the dampener chamber
Liquid leaks from the dampener	Screws on the housing are not properly tightened
Liquid comes out of the muffler	The diaphragm is damaged

2.4. Dismantling the dampener

The numbers put in brackets, refer to the part numbers in the spare parts drawing and spare parts list in chapter 3.



Before the dismantling procedure

Be sure to drain all liquid from the dampener. Cleanse or neutralize the dampener thoroughly. Disconnect the air connection and then the suction and discharge connections.

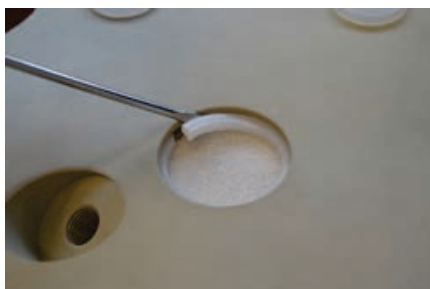

Fig. 2.4.1.
By means of a screwdriver, remove the circlip [27] and muffler [25].



Fig. 2.4.2.
Remove the nut covers [579] from the dampener housing and block.

2. MAINTENANCE

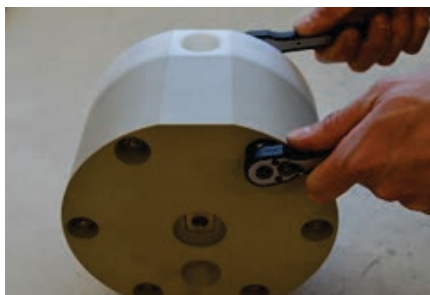

Fig. 2.4.3.
Using two spanners unscrew the nuts [37] cross-side and take them out alongside with the washers [38].



Fig. 2.4.4.
Take out the dampener block [12].



Fig. 2.4.5.
Take the pin screws [14] out of the dampener housing [11].



Fig. 2.4.6.
Unscrew the diaphragm [15] by hand (clockwise).



Fig. 2.4.7.
Using an allen key, unscrew the shaft ending [1652] from the diaphragm.



Fig. 2.4.8.
Push out the shaft [1651] from the dampener housing.

2. MAINTENANCE

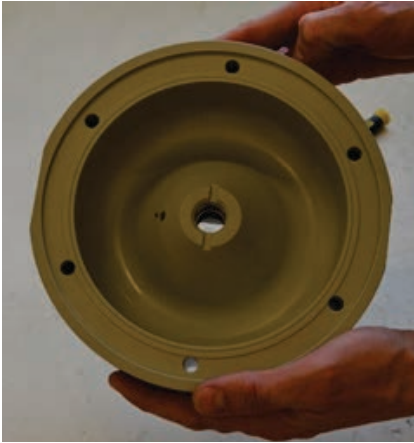

Fig. 2.4.9.

Check the inner seals [36] and O-rings [47]. If necessary, take them out using a screwdriver.

Note! If these parts are removed, they must be replaced with new ones. If the dampener sealing is worn, also check the shaft for wear and if necessary replace it.



Check all components and clean or repair if necessary. Clean the diaphragm from grease. If the diaphragm does not need to be replaced, apply grease.

2.5. Assembling the dampener

The numbers put in brackets, refer to the part numbers in the spare parts drawing and spare parts list in chapter 3.

It is of utmost importance to follow the assembly procedure. If one fails to comply with this procedure, injury or life hazard may occur when operating the dampener.

Assembly procedure



Fig. 2.5.1.

Using a screwdriver, insert the O-rings [47] into the dampener block [12].



Fig. 2.5.2.

Using a pair of pliers, insert the seals [36] into the dampener block [12]. To make the procedure easier bend the seals into a kidney shape and then fit them with a screwdriver.

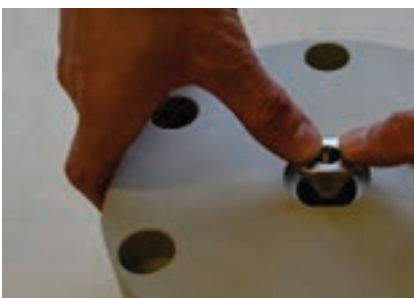

Fig. 2.5.3.

Push the shaft [1651] into the dampener block [12].

2. MAINTENANCE



Fig. 2.5.4.
Screw the shaft ending [1652] into the diaphragm [15].

Note! It is very important to screw the shaft ending (using an allen key) as deep as possible so it won't have the tendency to unscrew during operation.

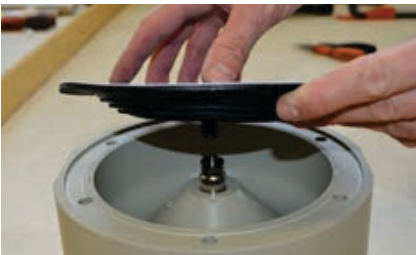

Fig. 2.5.5.
Screw the diaphragm [15] with the shaft ending [1652] onto the shaft [1651].

Note! When the diaphragm is screwed in, the holes in the diaphragm must be aligned with the holes in the block.



Fig. 2.5.6.
Push the diaphragm [15] in, so that it is touching the dampener block [12].

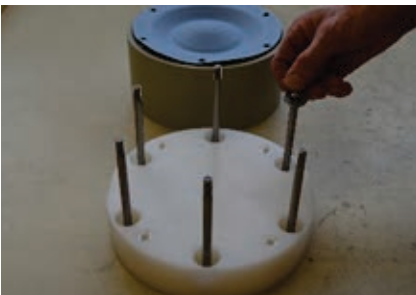

Fig. 2.5.7.
Put the pin screws [14] and washers [38] into the dampener housing [11].



Fig. 2.5.8.
Screw the nuts [37] onto the pin screws [14] so that ca. two threads are visible over the nut.



Fig. 2.5.9.
Turn over the dampener housing [11] and insert the dampener block [12] onto the pin screws [14].

2. MAINTENANCE



Fig. 2.5.10.
Insert the washers [38] and nuts [37] on the pin screws [14] from the side of the block and pre-tighten the nuts cross side.



Fig. 2.5.11.
Tighten the nuts [37] cross-side by means of a torque wrench with the appropriate torque (see chapter 4.2.).

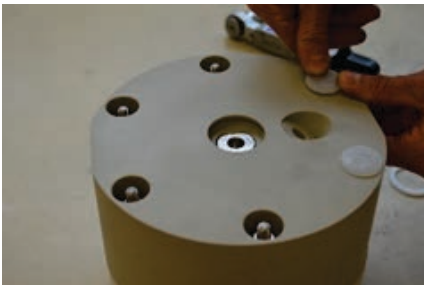

Fig. 2.5.12.
Insert the nut covers [579] on both sides of the dampener.

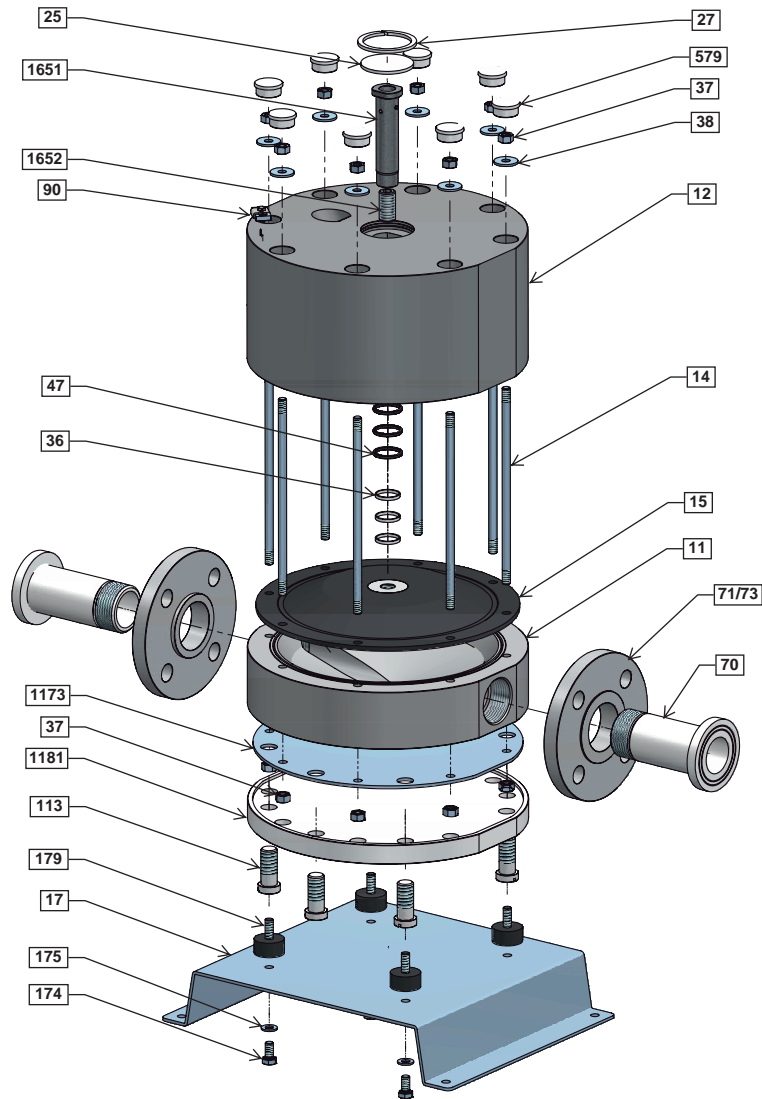

Fig. 2.5.13.
Insert the muffer [25] and the circlip [27] in a circular manner.

3. SPARE PARTS



3.1 Spare parts drawing – PE, PTFE and aluminium



3.2 Spare parts list – PE, PTFE and aluminium

POS	DESCRIPTION	QUANTITY
11	Dampener housing	1
113	Threaded insert	4
1173	Reinforcement plate	1 ***
1181	Cover	1 ***
12	Dampener block	1
14	Pin screw	4 / 6 / 8 *
15	Diaphragm	1
1651	Shaft	1
1652	Ending for shaft	1
17 (option)	Base	1
174 (option)	Socket head cap screw	4
175 (option)	Washer	4
179 (option)	Rubber foot	4
25	Muffler	1
27	Circlip	1
36	Seal (O-ring)	3
37	Nut	8 / 12 / 16 *
38	Washer	8 / 12 / 16 * PE, AL 4 / 6 / 8 * PTFE
47	O-ring	3 / 6 **
579	Nut cover	8 / 12 / 16 * PE, AL 4 / 6 / 8 * PTFE
70	Flange pipe (threaded)	2
71/73	Loose flange ring	2
90	Grounding set	1

* 4 / 8 in DT 9/20/25A; 6 / 12 in DT 50/70A and DT 100/120A; 8 / 16 in DT 200/220A, DT 400/420A and DT 800/820A

** 6 in DT 100/120A; 3 in the rest

*** only in PTFE execution

3. SPARE PARTS



3.3 Spare parts drawing – steel and sanitary

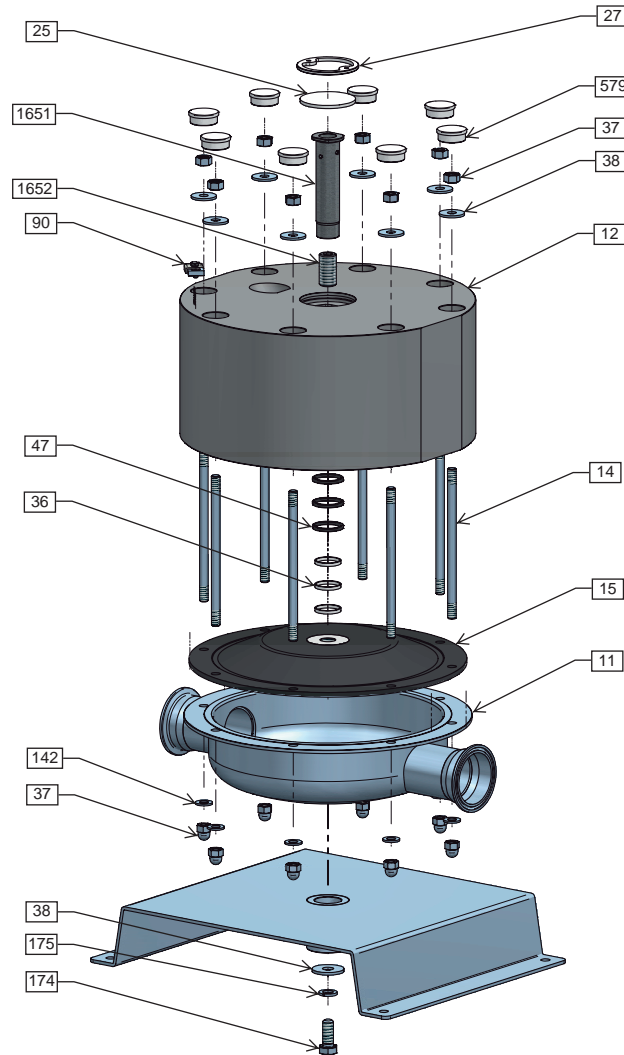

3.4 Spare parts list – steel and sanitary

POS	DESCRIPTION	QUANTITY
11	Dampener housing	1
12	Dampener block	1
14	Pin screw	4 / 6 / 8 *
142	Washer	4 / 6 / 8 *
15	Diaphragm	1
1651	Shaft	1
1652	Ending for shaft	1
174 (option)	Socket head cap screw	1
175 (option)	Washer	1
179 (option)	Rubber foot	4
25	Muffler	1
27	Circlip	1
36	Seal (O-ring)	3
37	Nut	8 / 12 / 16 *
38	Washer	4 / 6 / 8 *
47	O-ring	3
579	Nut cover	4 / 6 / 8 *
90	Grounding set	1

* 4 in DT 25S; 6 in DT 70S/80 and DT 120S; 8 in DT 220S/225, DT 420S/425 and DT 820S/825

3. SPARE PARTS



3.5 Recommended spare parts

Even at normal operation some elements in the dampener are subject to wear. In order to avoid expensive breakdowns we recommend having a few spare parts in stock. These are:

POS	SPARE PART	QUANTITY
15 25	Diaphragm Muffler	1 1

3.6 How to order parts

When ordering spare parts for Tapflo dampeners, it will simplify the process if you give **the model and serial number** from the nameplate of the dampener, position number of the part and quantity.

4. TECHNICAL DATA



4.1 Dimensions

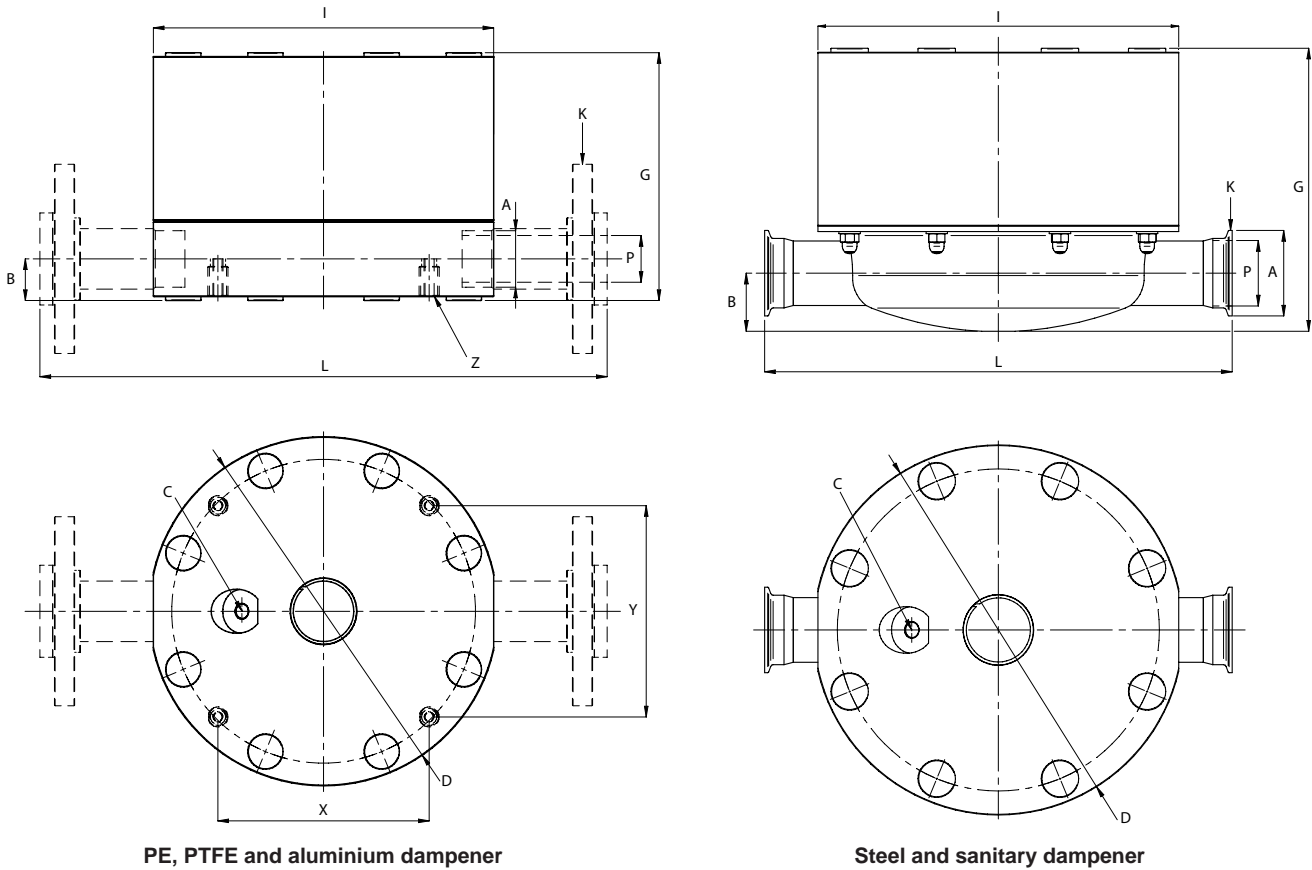

PE, PTFE and aluminium dampener

Steel and sanitary dampener

Dimensions in mm (where other is not indicated)
 Dimensions in inch (where other is not indicated)

DIMENSION	DAMPENER SIZE																				
	9/20	25	30	50	70	80	100	120	125	200	220	225	400	420	425	800	820	825			
A (BSP)	G 3/8"			G 1/2"			G 3/4"			G 1"			G 1 1/2"			G 2"			G 3 1/2"		
B	15/33 ¹	13	10,6	17/35 ¹	15,5	16,5	25,5/42,5 ¹	22,5	16,5	33/50 ¹	30	43,5	40,5/58 ¹	38	46	92	90	19,3			
	0,59/1,3 ¹	0,51	0,42	0,67/1,38 ¹	0,61	0,65	1/1,67 ¹	0,89	0,65	1,3/1,97 ¹	1,18	1,71	1,59/2,28 ¹	1,50	1,81	3,62	3,54	0,76			
C	G 1/8"			G 1/4"			G 1/4"			G 1/4"			G 1/4"			G 1/4"					
D	110			158			208			277			360			470					
	4,33			6,22			8,19			10,91			14,17			18,50					
G	85/103 ¹	81	78,5	109,5/129,5 ¹	105,5	117,5	144,5/161,5 ¹	141,5	135	200,5/217,5 ¹	197,5	216	244/261 ¹	241	256,5	394	392	330			
	3,35/4,06 ¹	3,19	3,09	4,31/5,1 ¹	4,15	4,63	5,69/6,36 ¹	5,57	5,31	7,89/8,56 ¹	7,78	8,50	9,61/10,28 ¹	9,49	10,10	15,51	15,43	12,99			
I	107			155			203			270			352			470					
	4,21			6,10			7,99			10,63			13,86			18,50					
K (BSP)	G 3/8"			G 1/2"			G 3/4"			G 1"			G 1 1/2"			G 2"			G 3 1/2"		
L	DIN & ANSI	235		285		375		450		550		700		-		-		-			
	Flange	9,25		11,22		14,76		17,72		21,65		27,56		-		-		-			
	BSP	107		155		203		270		352		470		-		-		-			
	Other Connections ³	-		180		210		300		350		450		600		-		-			
	-		7,09		8,27		11,81		13,78		17,72		23,62		-		-				
P (BSP)	G 3/8"			G 1/2"			G 3/4"			G 1"			G 1 1/2"			G 2"			G 3 1/2"		
X	36		90,3		113,8		167,6		226,3		297		-		-		-				
	1,42		3,56		4,48		6,60		8,91		11,69		-		-		-				
Y	86,8		100,3		135,6		167,6		226,3		297		-		-		-				
	3,42		3,95		5,34		6,60		8,99		11,69		-		-		-				
Z	M4x20	M4x17	-	M4x20	M4x17	-	M8x30/22 ¹	M8x25	-	M8x30/22 ¹	M8x25	-	M8x30/22 ¹	M8x25	-	M8x22 PTFE	M8x25	-			

1 PE / PTFE

2 ALU / SS

3 ISO 2852, DIN 11851, SMS1145, BS 4825 (RJT)

* Dimensions for other connections in next table

4. TECHNICAL DATA



DIMENSION		DAMPENER SIZE											
		9/20	30	50	80	100	125	200	225	400	425	800	825
A	DIN Flange	95 ⁵	95 ⁴	95 ⁵	105 ⁴	115 ⁵	115 ⁴	150 ⁵	150 ⁴	165 ⁵	165 ⁴	202 ⁵	200 ⁴
	ANSI	89 ⁶	90 ⁷	89 ⁶	100 ⁷	108 ⁶	110 ⁷	127 ⁶	125 ⁷	152 ⁶	150 ⁷	-	-
	ISO 2852	-	50,5	-	50,5	-	50,5	-	64	-	91	-	-
	DIN 11851	-	Rd 44x1/6"	-	Rd 52x1/6"	-	Rd 65x1/6"	-	Rd 78x1/6"	-	Rd 95x1/6"	-	Rd 110x1/4"
	SMS 1145	-	Rd 40x1/6"	-	Rd 40x1/6"	-	Rd 60x1/6"	-	Rd 70x1/6"	-	Rd 85x1/6"	-	-
(RJT) BS 4825	-	Rd 30x1/8"	-	Rd 46x1/6"	-	Rd 58x1/6"	-	Rd 72x1/6"	-	Rd 98x1/6"	-	-	
K	DIN Flange	DN15 ⁵	DN15 ⁴	DN15 ⁵	DN20 ⁴	DN25 ⁵	DN25 ⁴	DN40 ⁵	DN40 ⁴	DN50 ⁵	DN50 ⁴	DN80 ⁵	DN80 ⁴
	ANSI	1/2" ⁶	1/2" ⁷	1/2" ⁶	3/4" ⁷	1" ⁶	1" ⁷	1 1/2" ⁶	1 1/2" ⁷	2" ⁶	2" ⁷	-	-
	ISO 2852	-	DN 25	-	DN 25	-	1 1/2"	-	DN 50	-	DN 65	-	-
	DIN 11851	-	DN 20	-	DN 25	-	DN 40	-	DN 50	-	DN 65	-	DN 80
	SMS 1145	-	1" (25)	-	1" (25)	-	1 1/2" (38)	-	2" (51)	-	2 1/2"	-	-
(RJT) BS 4825	-	3/4"	-	1"	-	1 1/2"	-	2"	-	3"	-	-	
P	DIN Flange	10	17,3	10	22,9	22	29,7	37	44,3	48	56,3	80	80
		0,39	0,68	0,39	0,90	0,87	1,17	1,46	1,74	1,89	2,22	3,15	3,15
	ANSI	-	17,1	-	22,7	-	30,1	-	42,8	-	54,8	-	-
		-	0,67	-	0,89	-	1,19	-	1,69	-	2,16	-	-
	ISO 2852	-	22,6	-	22,6	-	35,6	-	49	-	66	-	-
		-	0,89	-	0,89	-	1,40	-	1,93	-	2,60	-	-
	DIN 11851	-	20	-	26	-	38	-	50	-	66	-	81
		-	0,79	-	1,02	-	1,50	-	1,97	-	2,60	-	3,19
	SMS 1145	-	22,6	-	22,6	-	35,6	-	48,6	-	60,6	-	-
		-	0,89	-	0,89	-	1,40	-	1,91	-	2,39	-	-
(RJT) BS 4825	-	15,8	-	22,2	-	34,7	-	47,6	-	73	-	-	
	-	0,62	-	0,87	-	1,37	-	1,87	-	2,87	-	-	

- 4 DIN 2642 , PN 10, loose montage
- 5 DIN PN10/16 (according to UNI 2277/2278)
- 6 FLANGE ANSI 150 (according to ASTM-A 182 SO/RF 150 lbs)
- 7 ANSI B16.5 150 lbs, loose montage

4.2 Tightening torques

DAMPENER SIZE	TIGHTENING TORQUE [Nm]
DT 9/20/25	6
DT 50/70/80	8
DT 100/120/125	16
DT 200/220/225	20
DT 400/420/425	23
DT 800/820/825	30

4.3 Dampener code

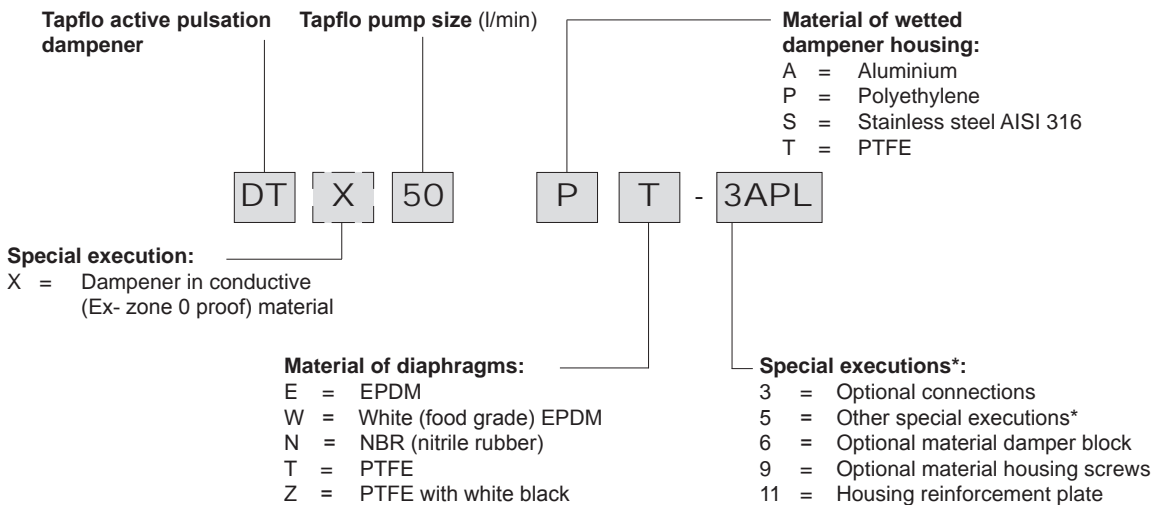

* = Ask us for complete pump code with all available options and executions. Changes reserved without notice



5.1 Returning parts

When returning parts to Tapflo AB please follow this procedure:

- Consult Tapflo AB for shipping instructions.
- Cleanse or neutralize and rinse the part/dampener. Make sure the part/dampener is completely empty from liquid.
- Pack the return articles carefully to prevent any damage during transportation.

Goods will not be accepted unless the above procedure has been complied with.

5.2 Warranty

Tapflo warrants products under conditions as stated below for a period of not more than 12 months from installation and not more than 24 months from date of manufacturing.

1. The following terms and conditions apply to the sale of machinery, components and related services and products, of Tapflo (hereinafter “the products”).
2. Tapflo (the manufacturer) warrants that:
 - a. its products as being free of defects in material, design and workmanship at the time of original purchase;
 - b. its products will function in accordance with Tapflo operative manuals; Tapflo does not guarantee that the product will meet the precise needs of the Customer, except for those purposes set out in any invitation to render documents or other documents specifically made available to Tapflo before entering into this agreement;
 - c. high quality materials are used in the construction of the pumps and that machining and assembly are carried out to the highest standards.

Except as expressly stated above, Tapflo makes no warranties, express or implied, concerning the products, including all warranties of fitness for a particular purpose.

3. This warranty shall not be applicable in circumstances other than defects in material, design, and workmanship. In particular warranty shall not cover the following:
 - a. Periodic checks, maintenance, repair and replacement of parts due to normal wear and tear (seals, O-rings, rubber items, bushings, etc.);
 - b. Damage to the product resulting from:
 - b.1. Tampering with, abuse or misuse, including but not limited to failure to use the product for its normal purposes as stated at the time of purchase or in accordance with Tapflo instructions for use and maintenance of the product, or the installation or improper ventilation or use of the product in a manner inconsistent with the technical or safety standard in force;
 - b.2. Repairs performed by non-skilled personnel or use of non-original Tapflo parts
 - b.3. Accidents or any cause beyond the control of Tapflo, including but not limited to lightning, water, fire, earthquake, and public disturbances, etc.;
4. The warrantee shall cover the replacement or repairing of any parts, which is documented faulty due to construction or assembling, with new or repaired parts free of charges delivered by Tapflo. Parts subjected to normal tear and wear shall not be covered by the warranty. Tapflo shall decide as to whether the defective or faulty part shall be replaced or repaired.

5. WARRANTY & REPAIR



5. The warrantee of the products shall be valid for a period in accordance to the current law from the date of delivery, under the condition that notice of the alleged defect to the products or parts thereof be given to Tapflo in written within the mandatory term of 8 days from the discovery. Repair or replacement under the terms of this warranty shall not give a right to an extension to, or a new commencement of, the period of warranty.
6. Repair or replacement under the terms of this warranty may be fulfilled with functionally equivalent reconditioned units. Tapflo qualified personnel shall be solely entitled to carry out repair or replacement of faulty parts after careful examination of the pump. Replaced faulty parts or components will become the property of Tapflo.
7. The products are built in accordance with standard CE normative and are tested (where applicable) by Tapflo. Approval and tests by other control authority are for the customer's account. The products shall not be considered defective in materials, design or workmanship if they need to be adapted, changed or adjusted to conform to national or local technical or safety standards in force in any country other than that for which the unit was originally designed and manufactured. This warranty shall not reimburse such adaptations, changes or adjustments, or attempt to do so, whether properly performed or not, nor any damage resulting from them, nor any adaptation, change or adjustments to upgrade the products from their normal purpose as described in the products operative manual without the prior written consent of Tapflo.
8. Installation, including electric and other connections to utility mains according to Tapflo drawings, is for the cost and responsibility of the customer, unless otherwise agreed in writing.
9. Tapflo will not be liable on any claim, whether in contract, tort, or otherwise, for any indirect, special, incidental, or consequential damages, caused to the customer or to third parties, including loss of profits, arising by any possible infringement of par. 3 above or by the customer or third parties being in the impossibility of using the products.

Steady the above, Tapflo liability to the customer or third parties from any claim, whether in contract, tort, or otherwise, shall be limited to the total amount paid by the customer for the product that caused the damages.

TAPFLO AB

Sweden

Filaregatan 4 | S-442 34 Kungälv

Tel: +46 303 63390

Fax: +46 303 19916

E-mail addresses:

Commercial questions: sales@tapflo.com

Orders: order@tapflo.com

Tech support: support@tapflo.com

Tapflo products and services are available in 68 countries on 6 continents.

Tapflo is represented worldwide by own Tapflo Group Companies and carefully selected distributors assuring highest Tapflo service quality for our customers' convenience.

AUSTRALIA | AUSTRIA | AZERBAIJAN | BELARUS | BELGIUM | BOSNIA & HERZEGOVINA | BRAZIL | BULGARIA | CANADA | CHILE | CHINA | COLOMBIA | CROATIA | CZECH REPUBLIC | DENMARK | ECUADOR | ESTONIA | FINLAND | FRANCE | GREECE | GEORGIA | GERMANY | HONG-KONG | HUNGARY | ICELAND | INDIA | INDONESIA | IRAN | IRELAND | ISRAEL | ITALY | JAPAN | JORDAN | KAZAKHSTAN | LATVIA | LITHUANIA | MACEDONIA | MALAYSIA | MEXICO | MONTENEGRO | MOROCCO | THE NETHERLANDS | NEW ZEALAND | NORWAY | POLAND | PORTUGAL | PHILIPPINES | ROMANIA | RUSSIA | SERBIA | SINGAPORE | SLOVAKIA | SLOVENIA | SOUTH AFRICA | SOUTH KOREA | SPAIN | SWEDEN | SWITZERLAND | SYRIA | TAIWAN | THAILAND | TURKEY | UKRAINE | UNITED ARAB EMIRATES | UNITED KINGDOM | USA | UZBEKISTAN | VIETNAM

Tapflo Group Companies

Austria

Tapflo Austria

Tel: +43 732 27292910

sales@tapflo.at

Azerbaijan

Tapflo Azerbaijan LLC

Tel: +994 502660799

sales@tapflo.az

Baltic States

Tapflo Latvia

Tel: +371 67472205

sales@tapflo.lv

Belarus

Tapflo Belarus

Tel: +375 17 3934609

sales@tapflo.by

Bulgaria

Tapflo EOOD

Tel: +359 (2) 974 18 54

office@tapflo.org

Canada

Tapflo Canada

Tel: +1 514 813 5754

canada@tapflo.com

Croatia

Tapflo GmbH

Tel: +385 91 4884 666

sales@tapflo.hr

Czech Republic

Tapflo s.r.o.

Tel: +420 513033924

tapflo@tapflo.cz

China

Tapflo (Wuxi)

Tel: +86 510 8241 7602

sales@tapflo.cn

Denmark

Tapflo Danmark

Tel: +45 36 454600

info@tapflo.dk

France

Tapflo France

Tel: +33 1 34 78 82 40

info@tapflo.fr

Georgia

Tapflo Georgia

Tel: +995 577 463010

sales@tapflo.ge

India

Tapflo Fluid Handling India

Pvt Ltd

Tel: +91 20 65000215

ad@tapflo.in

Ireland

Tapflo Ireland Ltd

Tel: +353 1 2011911

info@tapflo.ie

Italy

Tapflo Italia

Tel: +39 0362307698

info@tapfloitalia.com

Japan

Tapflo Japan K.K.

Tel: +81-3-6240-3510

tapflojp@tapflo.co.jp

Kazakhstan

Tapflo Kazakstan

Tel: +7 727 3278347

sales@tapflo.kz

Poland

Tapflo Sp. z o.o.

Tel: +48 58 530 42 00

info@tapflo.pl

Romania

S.C. Tapflo Rom. S.r.l.

Tel: +40 21 3451255

sales@tapflo.ro

Russia

Tapflo Company

Tel: +7 495 232 18 28

sales@tapflo.com.ru

Serbia

Tapflo d.o.o.

Tel: +381 21 44 58 08

sales@tapflo.rs

Slovakia

Tapflo s.r.o.

Tel: +421 911 137 883

tapflo@tapflo.sk

Slovenia

Tapflo GmbH

Tel: +386 68 613 474

ales@tapflo.hr

Spain

Tapflo Iberica

Tel: +34 91 8093182

avives@tapfloiberica.es

South Africa

Tapflo (Pty) Ltd

Tel: +27 31 701 5255

sales@tapflo.co.za

Turkey

Tapflo Makina Ltd

Tel: +90 216 467 33 11

sales@tapflo.com.tr

Ukraine

TOB Tapflo

Tel: +380 44 222 68 44

sales@tapflo.com.ua

Uzbekistan

Tapflo Uzbekistan

Tel: +998 712340940

sales@tapflo.uz

United Kingdom

Tapflo (UK) Ltd

Tel: +44 2380 252325

sales@tapflo pumps.co.uk